

AQUATROL 2000

OPTIMISER/COMPENSATOR CONTROLLER

with DHWS and Boiler Sequence Control

**AQUAPLAN SYSTEMS
APPLICATION MANUAL**

**AQUATROL 2000
AQUAPLANS**

Honeywell



*See page 56
for the new
AquaPacks*



Contents

Technical Data	2
General Description	3
Overview of Main Features	4 – 14
AquaPlan Quick Selection Chart	15
AquaPlan System Component Summary	16
AquaPlan System Applications	17 – 33
Mechanical Installation	35
Sensors	36 – 40
Temperature Sensor Characteristic	41
Electrical Installation	42 – 46
Installer/User Setup	47 – 51
Typical Specification	52 – 53
Valves and Actuators	54 – 55
AquaPack	56

Whilst Honeywell takes all reasonably practicable steps to design and manufacture its products to comply with the requirement of the Health and Safety at Work Act 1974, all products must be properly installed and used. Purchasers are reminded that their obligations under the Act are to ensure that the installation and operation of such products should be safe and without risk to health.

Honeywell reserves the right at any time and without notice to change any product or information contained in this publication.

Technical Data

Part number (includes standard base) **W6060C1067**

Control system Microprocessor control with analogue adjustments

Electrical Ratings:

Supply voltage 230V ac +10%/-15%
Nominal frequency 50Hz
Power consumption 8W

Relay ratings (230V):

Pumps and boilers 3A @ 0.6pf - 400,000 operations
Mixing valve 0.25A @ 0.4pf - 1,000,000 operations

Sensor Accuracy:

Water sensors 20°C to 90°C ±2K
Outside sensor -20°C to +20°C ±2K
Room sensor 10°C to 25°C ±0.5K

Environmental Requirements:

Ambient temperature 0 to 50°C
Humidity 0 to 90% non-condensing
Storage/Shipping temperature -30°C to +70°C

Electromagnetic Compatibility:

Emissions to EN55014
Susceptibility to EN50082-1

Protection (when installed to EN60529) IP40 (with base fitted)

Size and Weight:

Unit dimensions (w x h x d) 144 x 96 x 105mm (with standard base)
 144 x 153 x 109mm (with wiring centre)
Panel cut-out (w x h) 138 x 92mm
Weight 600 g

Factory Set Values:

Day (Comfort)
 space temperature 20°C
Night (Economy)
 space temperature 14°C
DHWS temperature 55°C
Summer/winter outside air
 temperature 20°C
Boiler cycle rate 6 cycles/hour
Mixed flow high limit
 temperature 90°C
Initial heating curve
 compensation slope 25
Boiler/mixed flow differential 10K

Time Programmes:

Heating 06:00 to 22:00 Monday to Sunday
DHWS 06:00 to 22:00 Monday to Sunday

System Selector Switches:

Actuator speed 4 minute
DHWS system Combined heating and DHWS
DHWS programme Time/temperature operation
DHWS priority Parallel DHWS and heating
Number of boilers 1
Heating system Radiator
Compensated heating mode Self adaptive
Boiler/mixed flow diff.
 OR boiler setpoint Boiler/mixed flow differential

General Description

The Aquatrol 2000 controller is the central component for a single zone low pressure hot water heating system. It provides optimum start and stop operation, sequence control of up to two boilers, outside air compensated mixed water control using a 3-port motorised valve and pump, and domestic hot water control using a valve and/or pump.

Self-adaptive optimisation enables the Aquatrol 2000, after a few days of operation, to accurately anticipate the optimum times to switch the heating plant on and off in order to minimise energy consumption without loss of occupant comfort levels. At the beginning of the preheat period and during a change from economy to day mode, the soft start feature slowly ramps up the heating supply water to reduce pipe expansion noises. This feature is useful for both conventional radiator or under floor heating circuits.

Compensated heating varies the heat output to adjust the flow temperature to match changes in the outside air temperature. Self-adaption is also applied to the compensated control loop to further increase the energy saving potential by providing automatic fine tuning of the compensated heating operating on the radiator system. Alternatively, compensated control of the boiler(s) can be provided.

Hot water to heat the domestic hot water (DHWS) can be sourced from the main heating boilers or can be provided for completely separately and independently. When hot water for the DHWS is selected as part of the main heating requirements, Aquatrol 2000 will automatically raise the boiler flow temperature to compensate for the additional load.

The main radiator heating and domestic hot water systems are both controlled by independent, 7 day time programmes offering 3 comfort and 3 economy periods per day. When heating is not required, the 'economy' period can be extended by using the holiday override function which allows the user to disable the heating and DHWS circuits for up to 99 days. Frost protection will be applied to both heating and DHWS.

Up to two boilers can be controlled in sequence with automatic lead/lag rotation on a weekly basis. The boiler firing rate can be set to match the manufacturer's optimum firing rate and to minimise mechanical damage. The boilers can also be set to provide hot water suitable for constant temperature and variable temperature systems simultaneously.

Automatic heating shutdown takes over whenever there is minimal demand for heating. Both the boilers and the heating pump are switched off. Before switching off, the heating pump will continue to run (pump overrun) for a variable period based on time or temperature in order to remove any residual heat from the boiler(s).

Automatic summer/winter changeover will switch off the heating pump and drive the 3-port mixing valve closed whenever the average outside air temperature exceeds a pre-set value during the last 24 hours. During the summer period both the 3-port mixing valve and the heating and domestic hot water pumps will be operated regularly (exercised) to prevent these components from sticking and jamming due to prolonged periods of inactivity.

Two override switches are provided. The Manual switch energises the output relays to override the controller, whilst the Service switch is provided for the service technician to run the heating system for routine maintenance during the annual shutdown period.

The controller has manually adjustable control knobs which ensure easy operation by the user.

An automatic installer check out routine enables the plant to be checked for both electrical and mechanical connections.

A range of compatible sensors plus a remote unit enables this controller to be used in a multitude of applications. The remote unit offers space temperature sensing plus manual adjustments to the setpoint, the operating mode and automatic time programme. When installed in conjunction with the space sensor, space temperature measurements are made by the space sensor freeing the manual override features to be located elsewhere for security and convenience. A wide range of valves and actuators complement the control system.

Overview of Main Features

INTRODUCTION

The Aquatrol 2000 controller is a multi-function controller offering many innovative automatic control functions. Many of these functions are automatically applied simply by connecting various temperature sensors. A range of alternative or optional control strategies can also be introduced for the user to take maximum advantage of this versatile controller.

Over the next few pages are the principle technical features available from the Aquatrol 2000. Many of these features can be switched on or off depending on the control strategies required. An easier way to establish which features are required for a particular application might be achieved by looking at the range of AquaPlans described later in this manual.

SOFT START

To reduce pipework/system expansion noises at the beginning of the boost or optimum start period, the soft start feature will restrict the mixed flow water temperature setpoint to 50°C (for radiator circuits) or 30°C (for under floor circuits) for a period of 15 minutes. If the mixed flow water temperature is already

close to this value (dependent on the position of System Selector Switch, S6), the soft start will not be initiated. See the section headed 'Heating Boost Period' below, for a graphical representation of the soft start feature.

OPTIMUM START

A space temperature sensor or remote unit or a combination of both must be fitted to obtain optimum start. The optimum start feature will preheat the space temperature to meet the day (comfort) temperature setpoint by occupancy. The controller will automatically estimate the length of the preheat period based on the current actual space temperature, the required day setpoint and past experience. When the time remaining until the setpoint change is less than or equal to the estimated preheat time, optimum start begins and continues until the day setpoint is achieved.

During preheat the rate of space temperature rise is continually monitored to improve the accuracy of future optimum start calculations. During this period the comfort 'flag' on the LCD will flash to indicate the controller is in the optimum start preheat mode. Preheat is restricted to a maximum of 6 hours.

No preheat period will occur if the difference between the space temperature and the space setpoint is less than or equal to 1K.

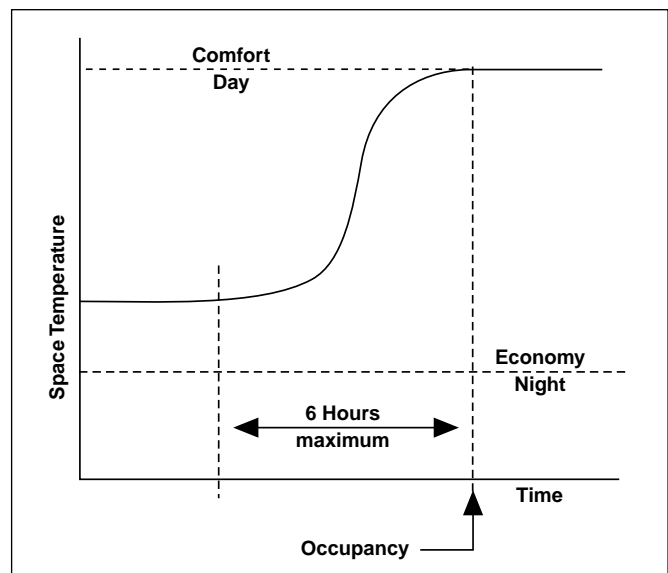

HEATING BOOST PERIOD

When neither a space temperature sensor nor a remote unit is fitted, the optimum start function will not apply. Instead, in order to boost the space temperature prior to occupancy, a boost period will occur by operating the boiler(s) at the maximum boiler flow temperature.

The boost period is restricted to a minimum of 15 minutes or a maximum of 60 minutes (for radiator circuits) or 120 minutes (for under floor circuits).

The length of the boost period is determined as follows:

Radiator Systems: Boost Period = $HCR \times 0.1 \times (\text{Day Space Setpoint} - T3_d)$
 Under floor Systems: Boost Period = $2 \times HCR \times 0.1 \times (\text{Day Space Setpoint} - T3_d)$
 where: HCR = Heating Curve Ratio (see page 5 for explanation)
 $T3_d$ = Delayed outside air temperature (see page 5 for explanation).

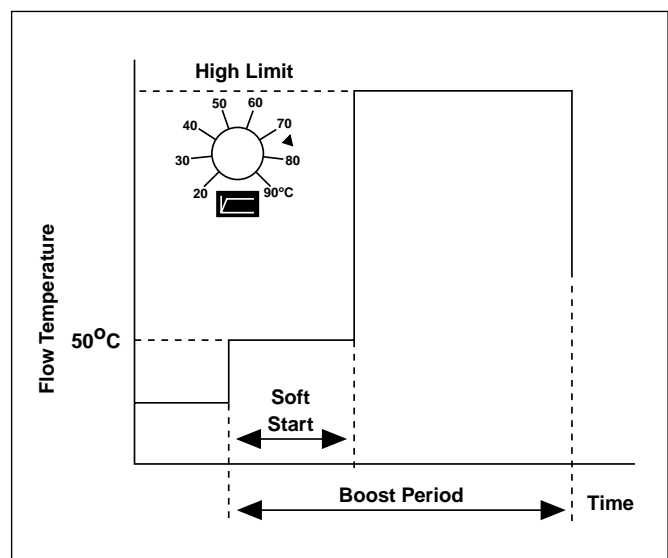

COMPENSATED TEMPERATURE CONTROL

Once the optimum start or boost period has terminated, operation of the heating system changes to compensated control of the mixed flow temperature. The compensation can be either fixed or self-adaptive.

Fixed Compensation:

Fixed compensation is often used when no representative space temperature measurement point can be found.

When neither a space temperature sensor nor a remote unit is fitted fixed compensation will occur. The heating curve ratio will remain constant at the initial setting left by the installer.

The recommended setting is 25 and, since no space temperature sensor is connected, System Selector Switch, S7 becomes ineffective and the value of P6 is not displayed.

If a space temperature sensor is fitted and fixed compensation is required, System Selector Switch, S7 must be set to position 'B'.

Self-Adaptive Compensation:

A space temperature sensor or a remote unit, or both, must be fitted to benefit from this feature. System Selector Switch, S7 must be set to position 'A'.

During normal heating periods, estimates are made for the heating curve ratio. Each day the controller compares its performance to meet the criteria of achieving the day space temperature exactly at occupancy.

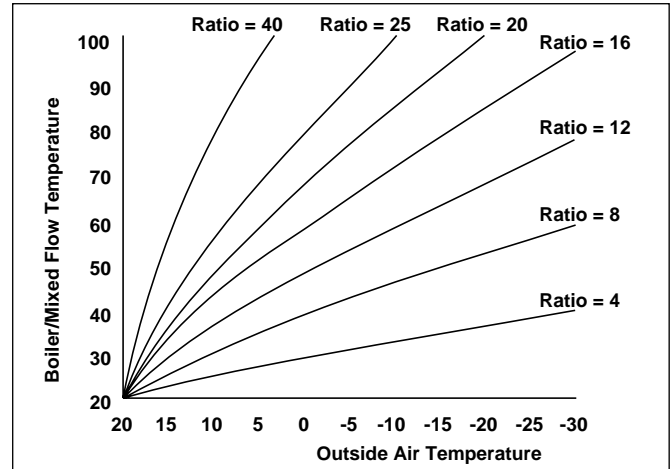

A new value for the heating curve ratio is stored daily in the controller's memory such that within 4 to 6 days, from initial start up, it will have changed the initial heating curve ratio to one that more closely matches the building's thermal characteristics. During this learning phase the room compensation will assist in providing comfortable space temperature conditions.

Estimates are not made whenever the controller is in optimum start or stop mode, during the boost period or when limits are exceeded, or when the heating pump is not running.

OUTSIDE AIR TEMPERATURE

Three 'values' of outside air temperature are used by the controller for various automatic functions. The controller provides a more cost effective and efficient control system when lagged (or delayed) outside air temperature measurements are used. Using lagged measurements ensures that irregular and unrepresentative values for the outside air temperature do not adversely affect features such as self-adaption or summer/winter changeover.

The graph shows how these three outside air temperature values compare with each other.

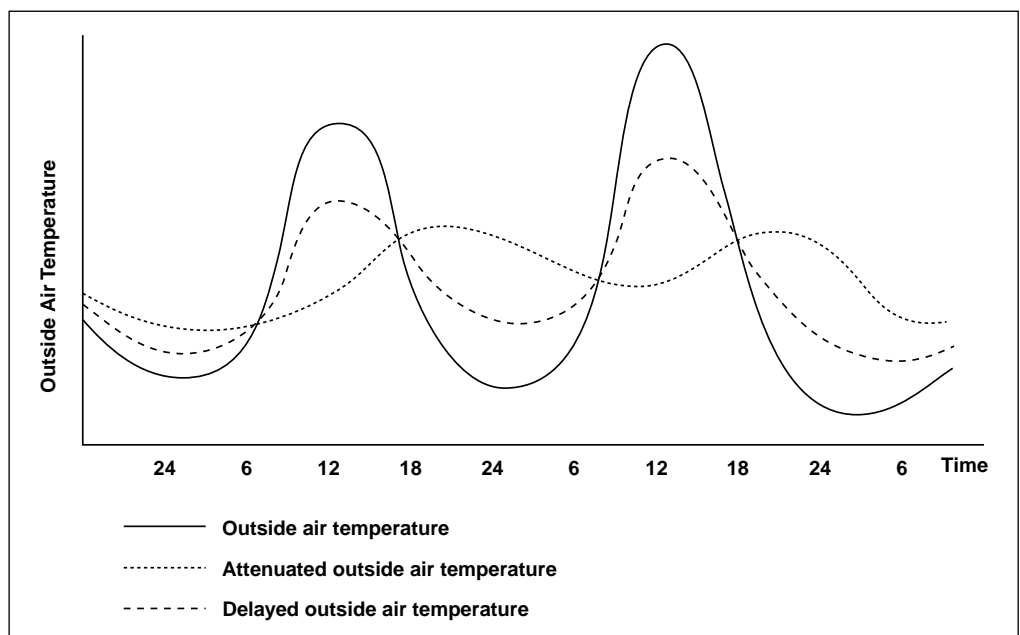

T_3 = the instantaneous outside air temperature is only used for outside air frost protection.

T_{3d} = the delayed outside air temperature is used for calculating the heating curve ratio. It imposes a 2 hour time lag on the measured value in order to ignore unrepresentative changes having a major effect on the heating system.

T_{3att} = the attenuated outside air temperature is used for automatic summer/winter changeover. It imposes a 24 hour time lag on the measured value in order to ensure that a no heating load condition persists.

BOILER CONTROL

Either a single boiler, or two boilers in sequence, can be controlled based on the highest temperature demand from the heating and/or the DHWS circuits. The demand from the heating circuit will be determined by whether or not the mixed flow temperature sensor is fitted.

Boiler Setpoint:

If no mixed flow temperature sensor is fitted, the controller assumes that only a heating circuit with no mixing valve exists, i.e. direct control of the boiler(s) firing. In this situation, the boiler(s) is/are controlled to the calculated setpoint based on the heating curve. System Selector Switch, S8 becomes ineffective.

If the mixed flow temperature sensor is fitted, the controller assumes that a mixing valve is installed on the heating circuit and control will be based on the position of System Selector Switch, S8. With the switch in position 'A' the demand from the heating circuit will be the calculated mixed flow setpoint plus an adjustable differential or the DHWS setpoint plus a fixed differential of 10K, whichever is the greatest.

This feature will not function when 'Standby', 'DHWS only', 'Holiday' and 'Summer' modes are selected.

Alternatively, with System Selector Switch, S8 in position 'B', the setting on the boiler setpoint knob will be the minimum permissible boiler flow temperature unless the demand for heating and/or DHWS is greater. With this combination of settings the heating provided by the boiler(s) can be used to simultaneously supply hot water to both variable and constant temperature circuits (heating and ventilation plants with their own local controls).

Note:

Refer to the wiring diagram on page 44 for additional safety circuitry required for combined variable and constant temperature systems.

Boiler Cycle Rate:

The boiler cycle rate is adjusted by the bottom left control knob to prevent the boilers from short cycling (by setting a minimum 'on' and a minimum 'off' firing period), to improve boiler efficiency, optimise life expectancy and reduce maintenance costs. The minimum 'on' and 'off' times are calculated as 20% of the cycle rate per hour:

$$\frac{60 \text{ minutes}}{\text{cycle rate}} \times 20\%$$

$$\text{Example: } \frac{60}{3} \times \frac{20}{100} = 4 \text{ minutes}$$

When the control knob is set to 3 the minimum 'on' and 'off' times are 4 minutes; with the control knob set to 12 the minimum 'on' and 'off' times are 1 minute.

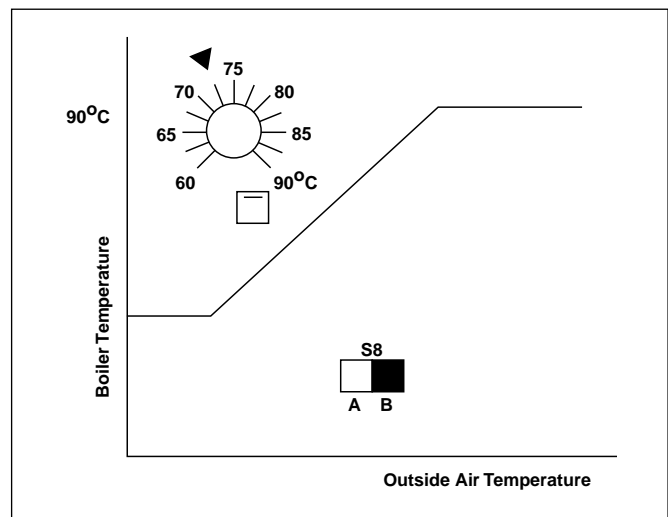
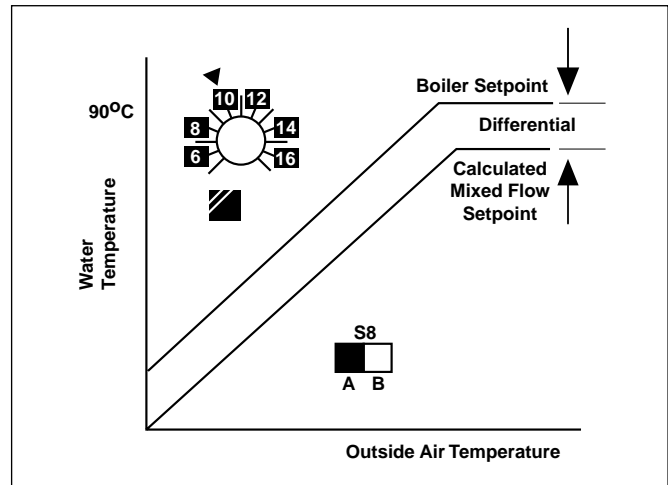
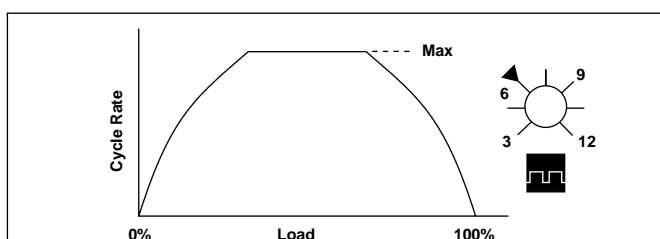

Boiler Sequence Control:

The number of boilers is selected by System Selector Switch, S5 - position 'A' = one boiler and position 'B' = two boilers. The boiler sequence is automatically rotated every Friday at 12:00 (midday). Note also that during the 'summer' period the mixing valve and the heating and DHWS pumps are exercised at the same time.

Note:

This feature only allows for sequence control of up to two boilers. It is not suitable for control of a single boiler with two burner stages. If you require the controller to provide sequence control of two boilers where the lead boiler must be a condensing boiler order controller **W6060C1117** instead. This model has the automatic lead boiler rotation feature inhibited.

Boiler Limits:

A fixed low limit at 0°C (with a differential of 2K) is applicable to the boiler temperature during periods when heating is in demand. The boiler(s) will be switched on if the water temperature falls below this value. The boiler minimum 'on' time will also be observed.

On reaching the fixed high limit at 90°C (with a differential of 2K) the boiler(s) will be switched off. The minimum 'off' time will be observed.

Supply/Mixed Flow High Limit Setpoint:

If no mixed flow temperature sensor is fitted, the boiler flow temperature is limited to the setting on the knob.

If the mixed flow temperature sensor is fitted, the mixing value will operate to maintain the maximum mixed flow temperature.

Note:

Where a constant temperature circuit is installed and System Selector Switch S8 is selected to position 'B' both the mixed flow **and** the boiler temperature sensors must be fitted.
In this configuration the high limit setpoint knob should be set to a value higher than the boiler minimum flow setpoint.
If a variable temperature circuit with a mixing valve is also required the mixed flow temperature sensor must be installed in the mixed flow pipe.
If no mixing valve is fitted the mixed flow and boiler temperature sensors must be installed adjacent to each other in the boiler flow header.

DOMESTIC HOT WATER SERVICE (DHWS)

DHWS can operate in one of two modes. Either the boiler(s) will provide hot water for both the heating and DHWS circuits combined, or the heating source for the DHWS is separate from the heating boiler(s), e.g. by using a stand-alone, gas-fired water heater.

Separate DHWS:

This method of operation is selected by fitting the DHWS temperature sensor and by setting System Selector Switch, S2 to position 'B'. The DHWS output is active when the DHWS temperature sensor falls 5K below the DHWS setpoint. The 'flag' on the LCD indicates the DHWS time programme is active and the LED indicates demand. In this configuration there will be no effect on the demand for heating by the boiler(s).

Combined DHWS:

There are three variants for combined DHWS; DHWS priority, shifting priority and parallel operation, all of which are selected by a combination of System Selector Switches, S2 and S4. In all three cases a demand for DHWS occurs when the DHWS temperature falls 5K below the DHWS setpoint. The boiler(s) is/are controlled at their fixed high limit value of 90°C until the DHWS temperature exceeds its setpoint.

1. DHWS Priority Operation:

In heating circuits with no mixing valve (and no mixed flow temperature sensor), the DHWS has priority over the heating. When a demand for DHWS exists the heating pump is switched off. System Selector Switch, S2 must be set to position 'A', whilst System Selector Switch, S4 becomes ineffective.

Priority is terminated when the boiler temperature is 20K above the DHWS setpoint. Under normal operation, if the DHWS temperature falls below the DHWS setpoint the heating is off until the boiler temperature exceeds the DHWS setpoint by 20K.

2. DHWS Shifting Priority Operation:

In heating circuits with a mixing valve where the boiler temperature is less than 10K above the DHWS setpoint the mixing valve will be closed giving the DHWS priority. If there is extra heat available and the boiler temperature is more than 20K above the DHWS setpoint, the mixing valve will be controlled at the calculated setpoint. The mixed water temperature setpoint is reduced when the boiler temperature lies between these two values.

System Selector Switches, S2 and S4 must both be set to position 'A'.

3. DHWS Parallel Operation:

In heating circuits with a mixing valve the heating circuit will operate normally during a demand for DHWS. System Selector Switches, S2 and S4 must be set to positions 'A' and 'B' respectively.

Note:

In some systems selecting parallel operation may result in extended DHWS recovery times or, in extreme cases, never being satisfied.

DHWS Pump Overrun:

Once the demand for DHWS has been met **and** no demand for heating exists, the DHWS pump will continue to run for a further 15 minutes to dissipate any residual heat. No overrun will occur if separate DHWS has been selected.

AUXILIARY TIME CONTROLLED OUTPUT

If the DHWS output is not required the output relay can be used to provide an independent time channel to operate any other piece of equipment, e.g. security lighting. This mode of operation can be selected by not fitting the DHWS sensor. System Selector Switches, S2 and S4 become ineffective.

When used in this mode, the 'flag' on the LCD will still appear but the LED will not be illuminated. Control of the boiler(s) is not affected.

OPTIMUM STOP

Optimum stop is used to save energy towards the end of occupancy provided it does not interfere with the occupants' comfort level. The controller will turn the plant off early provided that the predicted space temperature at the end of occupancy will not fall by 0.5K below the current space setpoint. The controller will estimate the time for the building to cool down based on the current actual space temperature, the space temperature setpoint and past experience.

The controller's performance will be monitored during the optimum off period to improve future optimum stop estimates. The maximum optimum off times are 60 minutes (for radiator circuits) and 120 minutes (for under floor circuits), respectively.

During the optimum stop period the night 'flag' on the LCD will flash. This is only an indication that optimum off operation is in progress. The day (comfort) setpoint will be maintained until the end of occupancy.

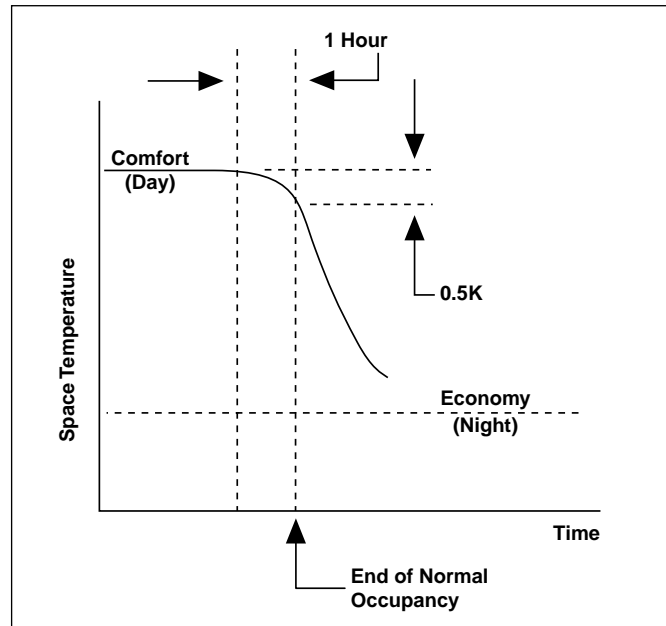

AUTOMATIC HEATING SHUTDOWN

When there is little or no demand for heating the controller will shut down the system and switch off the heating pump. The heating will shut down if any one of the following conditions occur:

- [1] The boiler water temperature is close to the space setpoint.
- [2] The space temperature is 2K above setpoint.
- [3] The optimum stop function has been invoked.
- [4] The night off condition has started.
- [5] The plant is manually switched into 'Standby' or 'DHWS only' modes.

The heating will automatically re-start when all of the above conditions no longer exist. If there is less than 30 minutes of the heating time programme left before the end of occupancy the plant will not re-start.

In order to dissipate any residual heat from the boiler(s) a variable time/temperature pump overrun occurs before the heating pump switches off. The heating pump will run for a minimum of 5 minutes and a maximum of 30 minutes, or will terminate if the boiler water temperature falls below 30°C. No pump overrun occurs if System Selector Switch, S8 has been set to position 'B', i.e. to allow for an independent constant temperature circuit to be operated from the boiler(s).

Note:

Background frost protection will switch the plant back on, except during a DHWS demand.

FROST PROTECTION

Background frost protection is applicable at all times.

Outside Air Frost Protection:

If the outside air temperature falls below 2°C, the controller will control the boiler water temperature at 30°C (for radiator circuits) and 15°C (for under floor circuits), or higher if the normal heating demand requires. The heating pump will be switched on. When the outside air temperature rises by 1K the frost protection action is terminated.

Space Frost Protection:

Space frost protection only occurs if a space temperature sensor or a remote unit, or both, is/are connected. If the space temperature falls below 4°C full heating is switched on, subject to the limit settings, until the space temperature rises by 1K.

Space frost protection has priority over every control mode except during the installer start-up sequence, if the DHWS has priority, or when the controller is switched into manual or service modes.

DHWS Frost Protection:

DHWS frost protection only occurs if a DHWS temperature sensor is fitted. If the DHWS temperature falls below 10°C, the DHWS pump is switched on and the boiler(s) is/are controlled at the boiler high limit setting (90°C) until the DHWS temperature rises by 5K.

AUTOMATIC SUMMER/WINTER CHANGEOVER

The heating circuit is shut down (heating pump switched off and mixing valve closed) when the average daily outside air temperature exceeds the summer/winter changeover setpoint as follows:

When $T_{3_{att}} >$ Summer/Winter changeover setpoint, the heating is switched off.

When $T_{3_{att}} <$ Summer/Winter changeover setpoint - 2K, the heating is switched on.

See page 5 for a graph and further explanation of the outside air temperature value used.

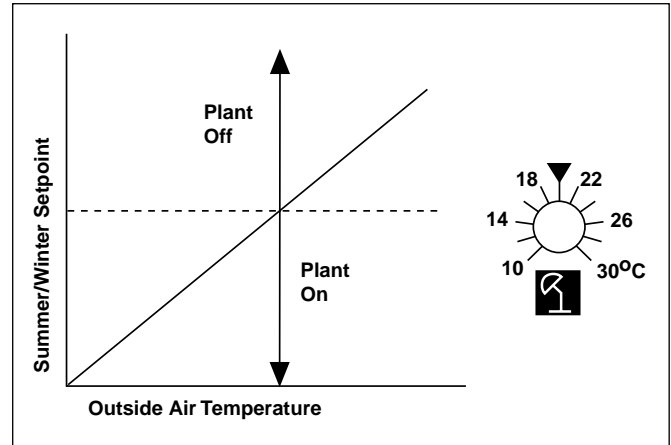

HOLIDAY MODE

By selecting the holiday mode the heating plant will operate at the night (economy) temperature setpoint or 'off' condition, and the DHWS is inactive (except for frost protection) until the number of holiday days has expired.

The LCD display indicates dynamically the number of holiday days remaining. Automatic control resumes from 0:00 on the first day heating is required again.

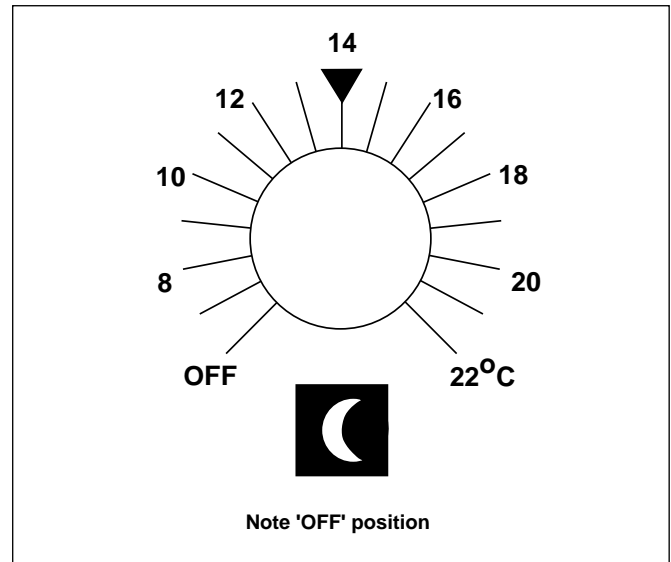

SERVICE SWITCH

Under normal operation switching the Service switch to the on position will control the boiler flow temperature at the high limit setting (90°C in mixed flow systems or the user set value in boiler only systems). When fitted, the mixing valve will continue to follow the calculated setpoint on the heating curve. Normal operation will resume as soon as the service switch is moved to the off position.

MANUAL OPERATION

Operating the Manual switch disconnects all the outputs from the micro-processor and sensor circuitry. Under manual operation the boiler(s) will fire, the heating and DHWS pumps will run and the mixing valve will remain at its last position. To move the mixing valve to a different position engage the manual operator on the actuator.

INSTALLER START-UP SEQUENCE

To assist the installer on initial start-up the controller runs through a pre-determined series of operations to prove the electrical and mechanical installation. All system components and all output relays are exercised.

The complete sequence of events lasts approximately 7 minutes.

It is initiated by moving the Service switch to the "I" position before applying power. It can be repeated as many times as required by switching the power on and off, and can be stopped at any time by moving the Service switch to the "0" position.

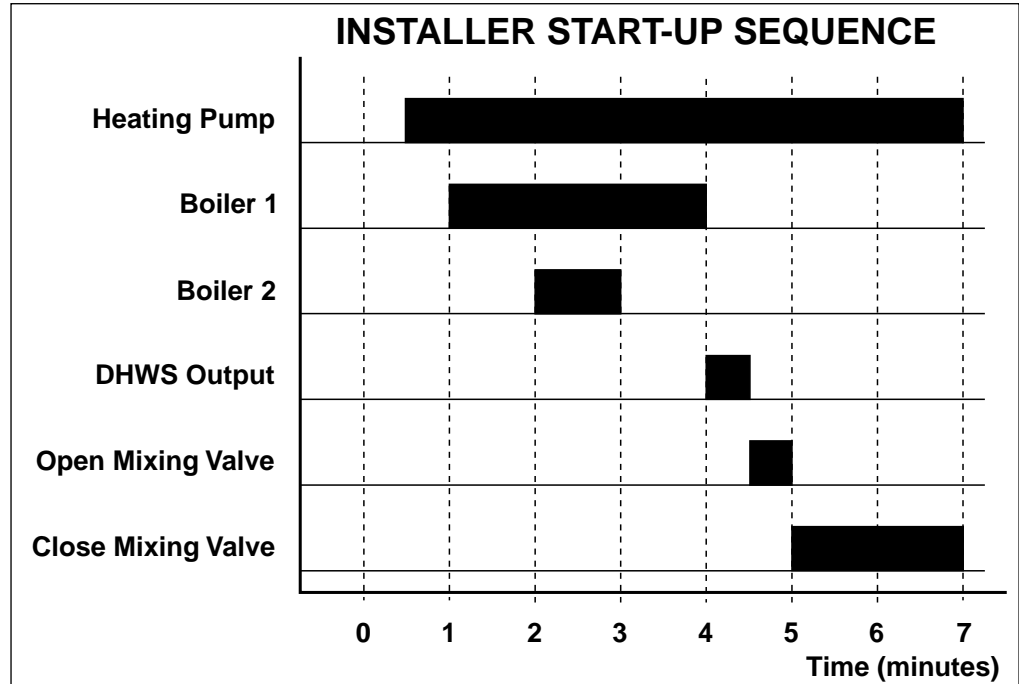

PUMP AND VALVE EXERCISE

To prevent the mixing valve and the heating and DHWS pumps from sticking and jamming due to prolonged periods of inactivity, a valve and pump exercise programme is activated weekly at 12:00 (midday) on Fridays for approximately 2 minutes in total. Note that the lead boiler rotation also takes place at this time.

The valve and pump exercise programme will only occur if there is no heating demand.

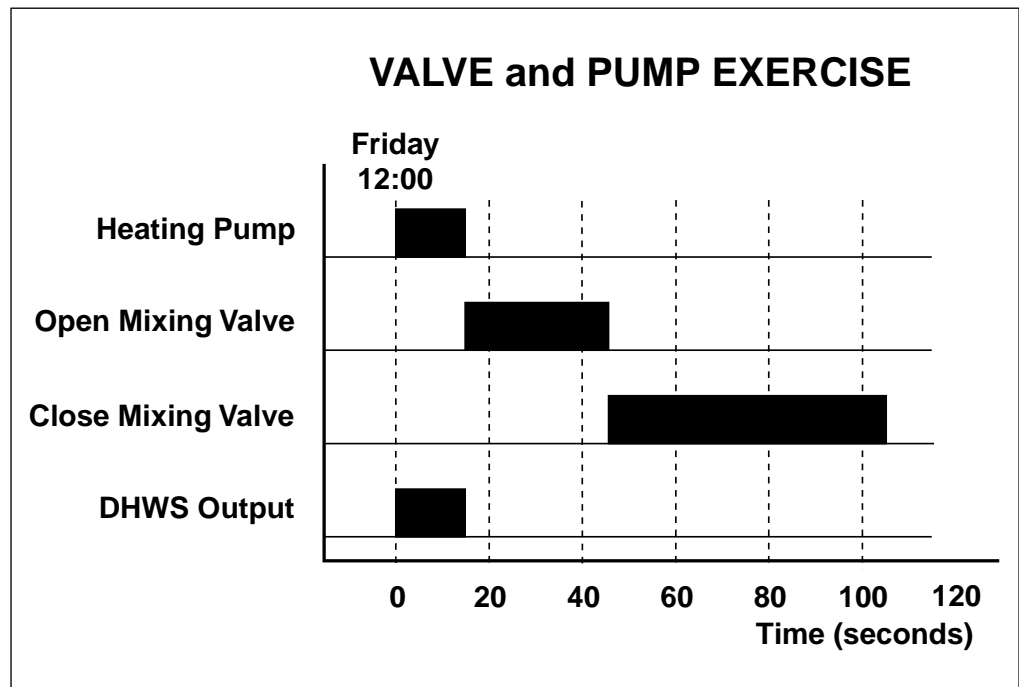

FAULT CODES

The system fault codes will be displayed on the LCD as follows:

Fault Code	Description	Controller Action
F1	Not used	
F2	Mixed flow temperature sensor fault	Acts as a system without a mixing valve
F3	Outside air temperature sensor fault	Heating is switched on at frost protection levels
F4	Not used	
F5	DHWS temperature sensor fault	DHWS output is held off
F6	Boiler flow temperature sensor fault	Under frost conditions: the boiler cycles at 20%. No frost condition: the boiler is off
F7	Space temperature sensor fault	Acts as a system without a room temperature sensor
F8	Internal fault	Boiler cycles at 20%. Mixing valve opens
F9	Remote unit fault	Acts as a system without remote unit

The above table is shown in priority order. If more than one fault exists, the fault with the lowest number has the highest priority.

A temperature sensor or remote unit fault indicates a short or open circuit condition at the corresponding input terminals. If an open circuit condition exists the LCD will display "--", whereas a short circuit condition will display "00".

Note:

An open circuit condition on start-up is used as part of the automatic self-configuring process. A fault will not be displayed if the controller has been initially configured without the appropriate temperature sensor or remote unit.

TEMPERATURE AND PARAMETER ENQUIRY

By switching to the enquiry mode all system temperatures and the adapted heating curve value (or the value of the heating curve compensation slope knob if fixed compensation is selected by System Selector Switch, S7 being moved to position B) can be displayed on the LCD. Only the current temperatures and parameter value will be displayed. This facility is not available during the initial start-up procedure.

Display Code	Description	Range
T1	Space temperature	0 to 35
T2	Mixed water temperature	0 to 99
T3	Outside air temperature	-30 to +30
T4	DHWS temperature	0 to 99
T5	Boiler water temperature	0 to 99
P6	Adaptive heating curve ratio	4 to 40

AUTOMATIC SENSOR RECOGNITION

During the first minute of operation the controller automatically detects those sensors connected to determine the application. If any sensor is changed re-initialise the controller by switching off the power.

If T2 is present, a mixing valve is assumed.

If T5 is present, one or more boilers is/are assumed. If not T5 assumes control. If the system is heating and DHWS T5 must be fitted.

If a space temperature sensor and/or a remote unit are present room compensation, self adaption and heating optimisation are enabled.

If T4 is present, the DHWS functions are enabled.

Manual Adjustments

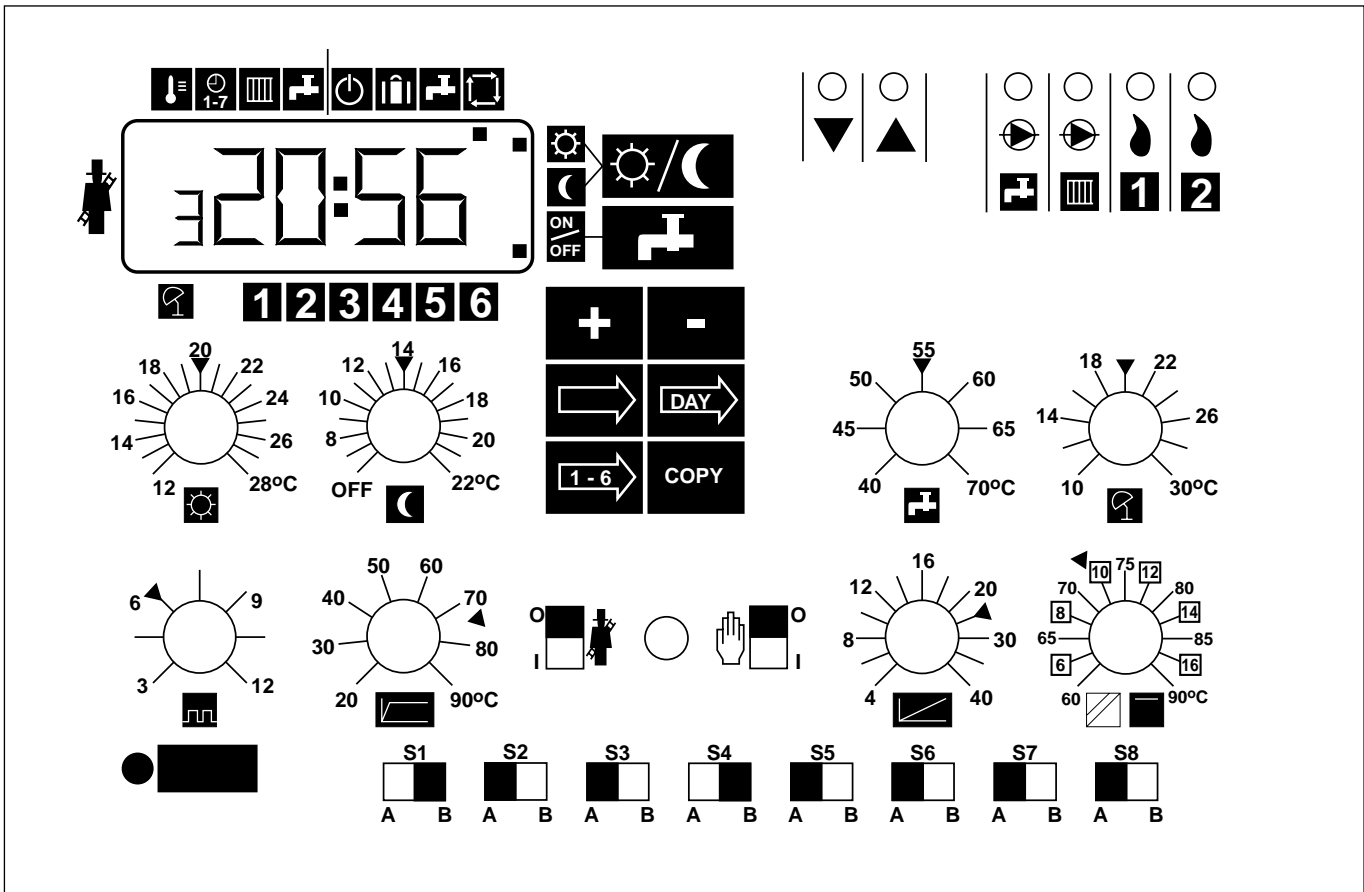

Manual adjustments are achieved in four ways:

[1] Eight Control knobs (initially all set by the installer). The top four can be adjusted by the user by lowering the clear perspex cover. The bottom four knobs are hidden behind a cover secured by a screw.

[2] Eight System Selector Switches (all set by the installer).
 [3] Two Special Switches for manual override and servicing.
 [4] A Keypad with eight membrane keys for custom programming.

Control Knobs



	Day (comfort) space temperature setpoint. Range: 12 to 28deg.C. Default: 20 deg.C.		Boiler cycle rate. Range: 3 to 12 cycles per hour. Default: 6 cycles per hour.
	Night (economy) space temperature setpoint with 'off' position. Range: 8 to 22 deg.C. Default: 14 deg.C.		Supply/Mixed flow high limit setpoint. Range: 20 to 90 deg.C. Default: 75 deg.C.
	Domestic hot water temperature setpoint. Range: 40 to 70 deg.C. Default: 55 deg.C.		Initial heating curve compensation slope. Range: 4 to 40. Default: 25.
	Automatic summer/winter (heating enable/disable) temperature setpoint. Range: 10 to 30 deg.C. Default: 20 deg.C.		Boiler/mixed flow differential (selected by Switch S8). Range: 6 to 16K. Default: 10K.
			Boiler minimum flow temperature setpoint (selected by Switch S8). Range: 60 to 90 deg.C. Default: 72 deg.C.

System Selector Switches

System Selector Switches			(Factory settings shaded grey)
Switch	Description	Position A	Position B
S1	Actuator speed for 3-port mixing valve.	1 minute valve actuator.	4 minute valve actuator.
S2	DHWS system type.	Combined boilers for heating and DHWS.	Separate DHWS. Boilers only serving heating.
S3	DHWS programme override.	Normal time/temperature operation.	Continuous temperature operation.
S4	DHWS priority operation.	DHWS priority on start up until the boiler temperature is 20K above the DHWS setpoint.	Parallel DHWS and heating operation.
S5	Number of boilers.	1 boiler.	2 boilers in sequence with automatic lead boiler changeover on Friday at 12:00.
S6	Type of heating system.	Radiator system.	Under floor heating system.*
S7	Compensated heating mode.	Self adapting mode.	Fixed mode.
S8	Boiler/mixed flow differential OR Boiler minimum flow temperature.	Boiler setpoint operating at an adjustable differential above the calculated mixed flow setpoint.	Adjustable boiler setpoint to control the boilers at a constant temperature setpoint to serve constant and variable temperature circuit.
S1, S4 and S8 become ineffective if the mixed flow temperature sensor is not fitted.			
S2 and S4 become ineffective if the DHWS temperature sensor is not fitted.			
S7 becomes ineffective if the room temperature sensor is not fitted.			

* Remember to set the supply/mixed flow high limit setpoint lower than 75°C.

Special Switches

Manual Override		The output relays are set such that the boilers, heating and DHWS pumps are switched on and the 3-port mixing valve has no power, allowing the 3-port mixing valve to be positioned using the manual override feature on the actuator.
Service Switch		Under normal operation the boiler temperature is controlled to the boiler high limit (90°C in mixed flow systems or user set high limit in boiler only systems). The 3-port mixing valve will continue to control to the current calculated heating setpoint on the heating curve.

Keypad

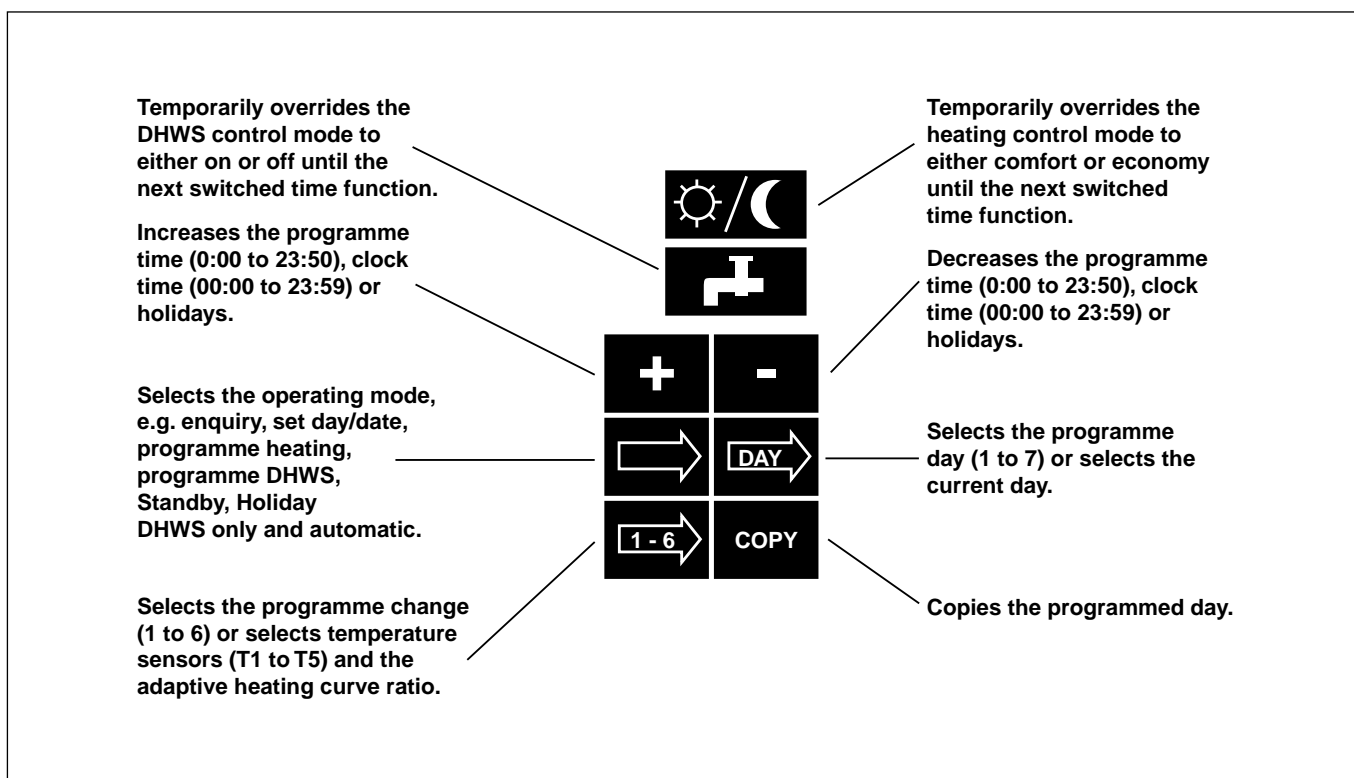

None of these keys are active whilst the controller is in either the manual override or service modes.

By simultaneously pressing the '+' and '-' keys for 5 seconds while in automatic mode all programmed and learned parameters will be returned to the factory default settings.

Note:

If fewer than 6 switching time point entries are made always start at switching point number 1 and enter all subsequent switching times in strict sequence. Leave all unused switching times set to 00:00.

DEFAULT FACTORY TIME PROGRAMMES

Switching Point	Heating Monday - Sunday	DHWS Monday - Sunday
1	06:00	06:00
2	22:00	22:00
3	00:00	00:00
4	00:00	00:00
5	00:00	00:00
6	00:00	00:00

The Aquatrol 2000 will retain the heating and DHWS time programmes and learned parameters indefinitely. The actual time and date will need to be reset after a mains voltage power failure exceeding 12 hours.

AquaPlan Quick Selection Chart

To use this chart start at the top by answering the questions in the shadowed boxes. If the answer is "Yes" follow the selection path to find the letter which corresponds to the AquaPlan required to meet the application.

AquaPlan

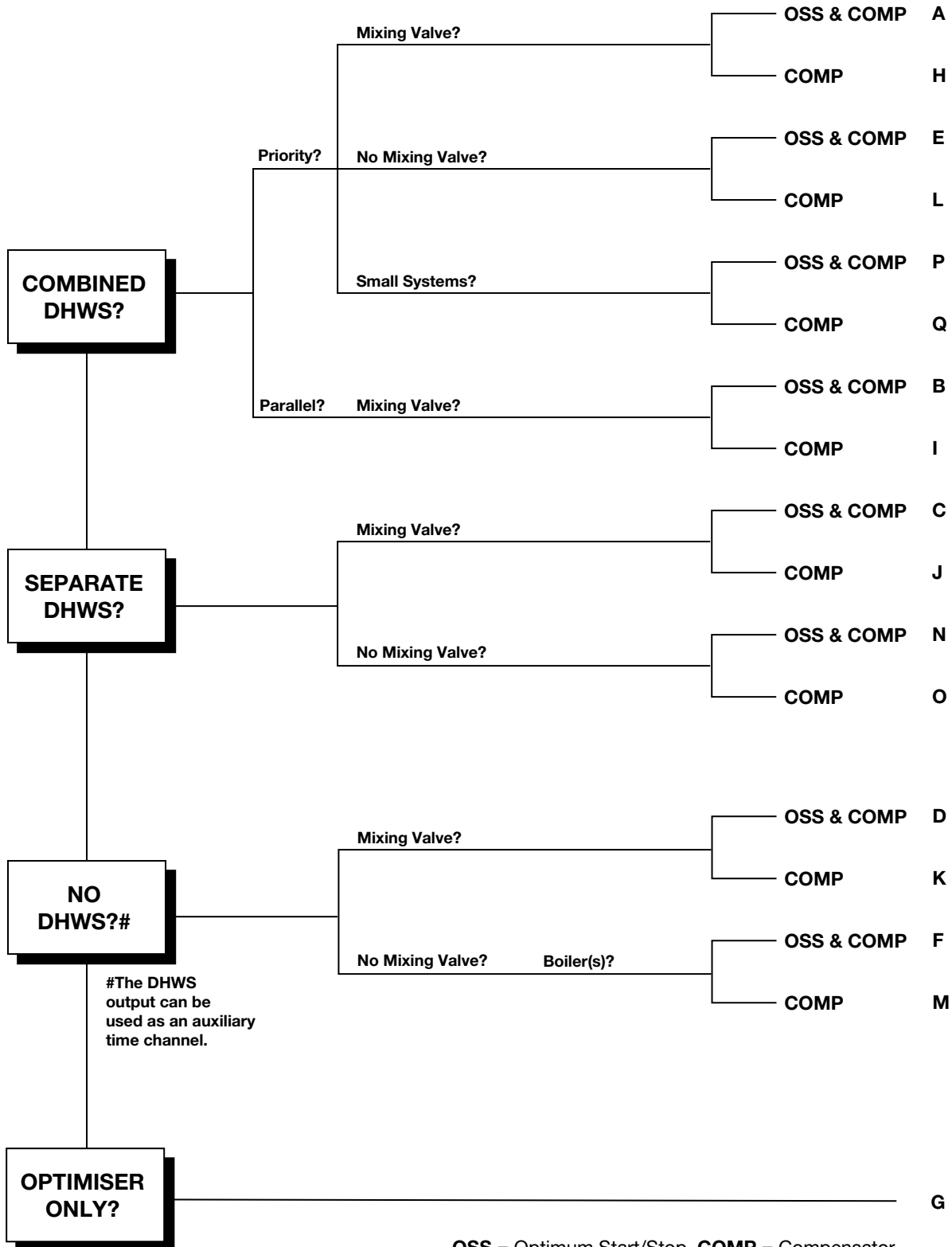

AquaPlan System Component Summary

AquaPlan System		Temperature Sensors					Page No.
No.	Description	Space *	Mixed Flow	Outside Air	DHWS	Boiler	
A	Optimiser, Compensated Heating, Boiler(s) and DHWS (shifting priority)	1	1	1	1	1	17
B	Optimiser, Compensated Heating, Boiler(s) and DHWS (parallel operation)	1	1	1	1	1	18
C	Optimiser, Compensated Heating, Boiler(s) and DHWS (separate)	1	1	1	1	1	19
D	Optimiser, Compensated Heating, Boiler(s) with Auxiliary Output (optional)	1	1	1	–	1	20
E	Optimiser, Direct Compensated Boiler(s) and DHWS (priority)	1	–	1	1	1	21
F	Optimiser, Direct Compensated Boiler(s) with Auxiliary Output (optional)	1	–	1	–	1	22
G	Optimiser only	1	–	Fixed Resistor	–	–	23
H	Compensated Heating, Boiler(s) and DHWS (shifting priority)	–	1	1	1	1	24
I	Compensated Heating, Boiler(s) and DHWS (parallel operation)	–	1	1	1	1	25
J	Compensated Heating, Boiler(s) and DHWS (separate)	–	1	1	1	1	26
K	Compensated Heating, Boiler(s) with Auxiliary Output (optional)	–	1	1	–	1	27
L	Direct Compensated Boiler(s) and DHWS (priority)	–	–	1	1	1	28
M	Direct Compensated Boiler(s) with Auxiliary Output (optional)	–	–	1	1	1	29
N	Optimiser, Direct Compensated Boiler(s) Output (optional)	1	–	1	1	1	30
O	Direct Compensated Boiler(s) and DHWS (separate)	–	–	1	1	1	31
P	Small System Optimiser, Direct Compensated Boiler(s) and DHWS (priority)	1	–	1	1	1	32
Q	Small System Direct Compensated Boiler(s) and DHWS (priority)	–	–	1	1	1	33

* If 'fixed' optimisation or compensation is required instead of 'self-adaptive', delete the space temperature sensor(s). Both the full function and/or the simple space temperature sensor can be combined together to provide greater flexibility.

Optimiser, Compensated Heating, Boiler(s) and DHWS (shifting priority)

APPLICATION

This plan provides optimum start/stop for the heating plant based on the controller's time programme with compensated heating via a mixing valve. Boiler sequence control maintains optimum heat to the heating and DHWS circuits. The DHWS provides independent, programmable time and temperature control with variable priority dependant on demand.

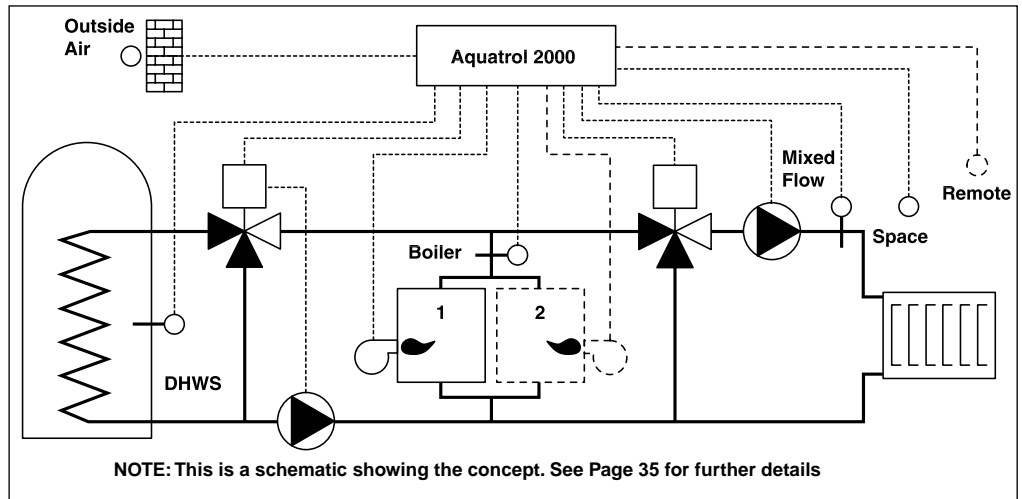

System Selector Switches		Set	Qty	System Components	
S1	Actuator speed	#	1	W6060C1067	Aquatrol 2000 controller
S2	DHWS System type	A	1	T7043E1008	Outside air sensor
S3	DHWS Programme override	A	3*	T7043F1006	Immersion sensor OR
S4	DHWS Priority operation	A	3*	T7044C1002	Strap-on sensor
S5	Number of boilers	#	1	T8102B1027	Space sensor
S6	Type of heating system	A	*Or combination to a total of 3 water sensors		
S7	Compensated heating mode	A	OPTIONS:		
S8	Boiler/mixed flow differential or boiler setpoint selection	#	1	K42007745-005	Wiring centre
# = Set to position 'A' or 'B' to suit the specific application.			1	T8102B1001	Remote unit with setpoint adjustment, manual override switch and extension function
Factory settings shaded grey.					

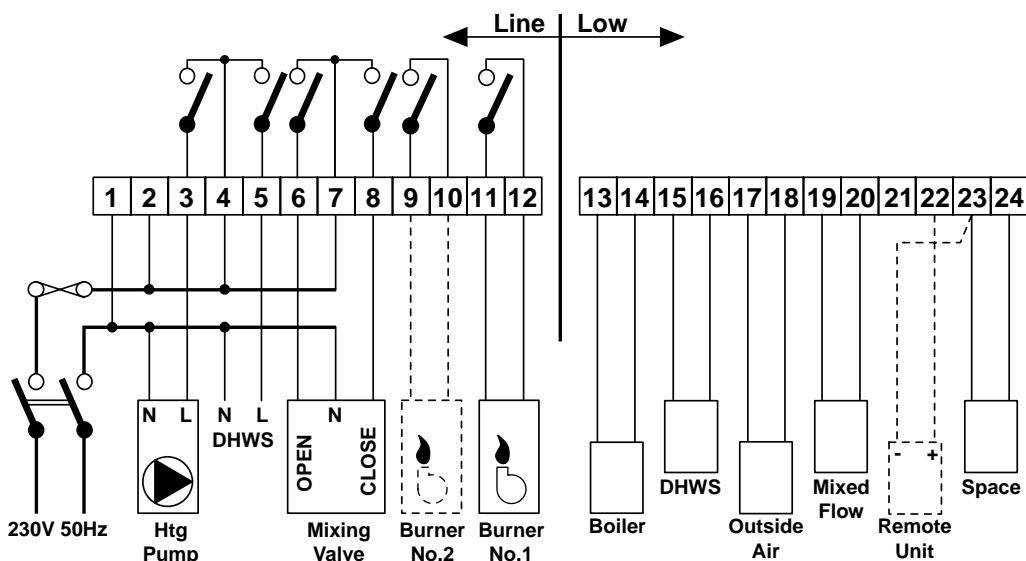

See Page 43 for DHWS and Burner wiring

See Page 42 for Temperature Sensor wiring

Optimiser, Compensated Heating, Boiler(s) and DHWS (parallel operation)

APPLICATION

This plan provides optimum start/stop for the heating plant based on the controller's time programme with compensated heating via a mixing valve. Boiler sequence control maintains optimum heat to the heating and DHWS circuits. The DHWS provides independent, programmable time and temperature control in parallel with the heating circuit.

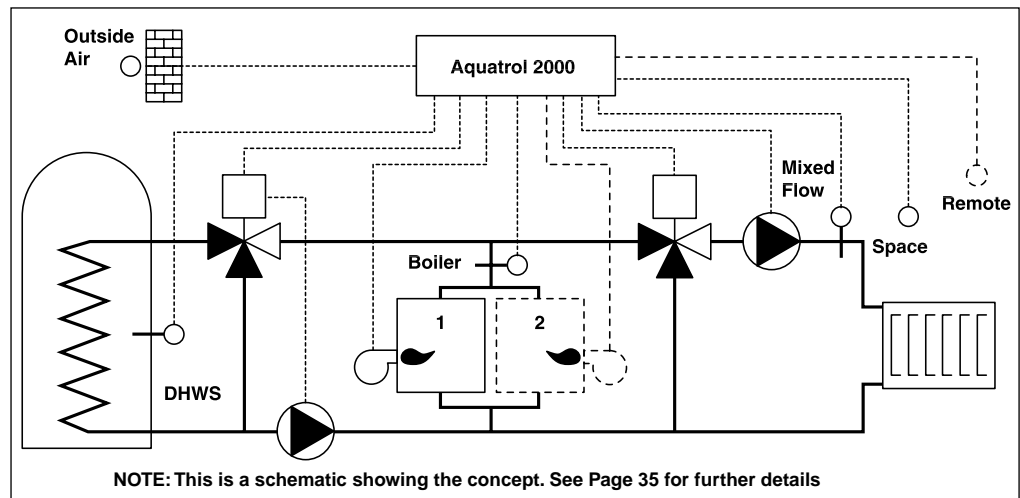

System Selector Switches		Set	Qty	System Components	
S1	Actuator speed	#	1	W6060C1067	Aquatrol 2000 controller
S2	DHWS System type	A	1	T7043E1008	Outside air sensor
S3	DHWS Programme override	A	3*	T7043F1006	Immersion sensor OR
S4	DHWS Priority operation	B	3*	T7044C1002	Strap-on sensor
S5	Number of boilers	#	1	T8102B1027	Space sensor
S6	Type of heating system	A	*Or combination to a total of 3 water sensors		
S7	Compensated heating mode	A	OPTIONS:		
S8	Boiler/mixed flow differential or boiler setpoint selection	#	1	K42007745-005	Wiring centre
# = Set to position 'A' or 'B' to suit the specific application.			1	T8102B1001	Remote unit with setpoint adjustment, manual override switch and extension function
Factory settings shaded grey.					

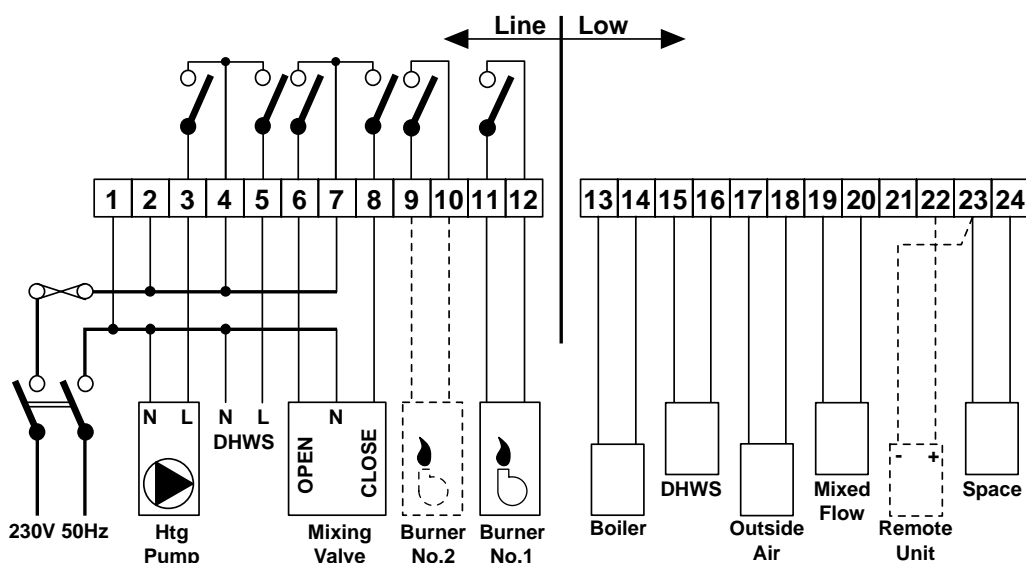

See Page 43 for DHWS and Burner wiring

See Page 42 for Temperature Sensor wiring

Optimiser, Compensated Heating, Boiler(s) and DHWS (separate)

APPLICATION

This plan provides optimum start/stop for the heating plant based on the controller's time programme with compensated heating via a mixing valve. Boiler sequence control maintains optimum heat to the heating circuit. The DHWS provides independent, programmable time and temperature control separate from the heating boiler(s).

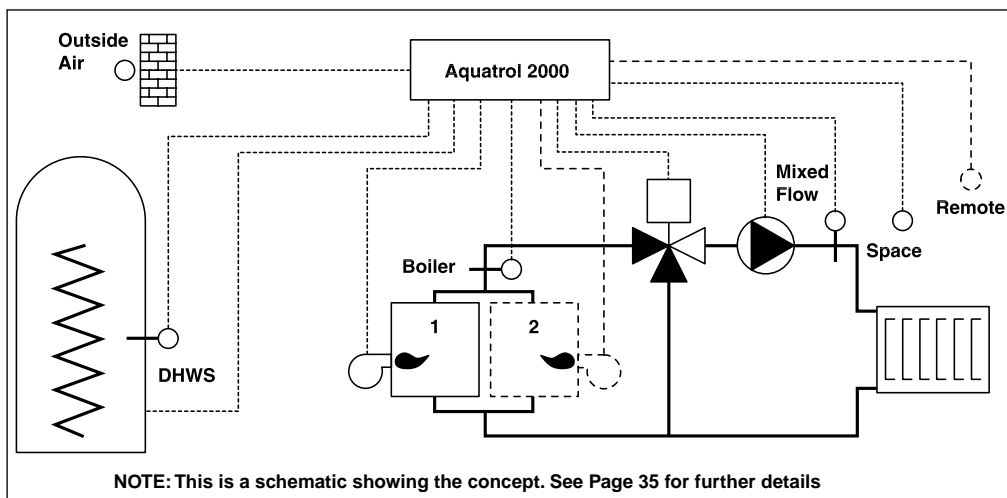

System Selector Switches		Set	Qty	System Components	
S1	Actuator speed	#	1	W6060C1067	Aquatrol 2000 controller
S2	DHWS System type	B	1	T7043E1008	Outside air sensor
S3	DHWS Programme override	A	3*	T7043F1006	Immersion sensor OR
S4	DHWS Priority operation	B	3*	T7044C1002	Strap-on sensor
S5	Number of boilers	#	1	T8102B1027	Space sensor
S6	Type of heating system	A	*Or combination to a total of 3 water sensors		
S7	Compensated heating mode	A	OPTIONS:		
S8	Boiler/mixed flow differential or boiler setpoint selection	#	1	K42007745-005	Wiring centre
# = Set to position 'A' or 'B' to suit the specific application.			1	T8102B1001	Remote unit with setpoint adjustment, manual override switch and extension function
Factory settings shaded grey.					

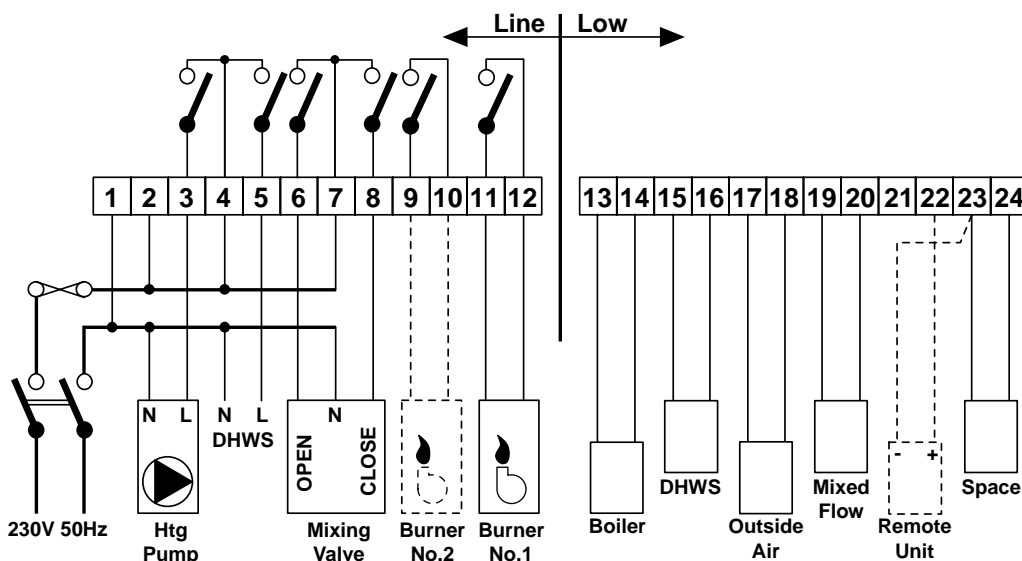

See Page 43 for DHWS and Burner wiring

See Page 42 for Temperature Sensor wiring

Optimiser, Compensated Heating with Auxiliary Output (optional)

APPLICATION

This plan provides optimum start/stop for the heating plant based on the controller's time programme with compensated heating via a mixing valve. Boiler sequence control maintains optimum heat to the heating circuit. The DHWS output provides independent, programmable time control of an auxiliary electrical load.

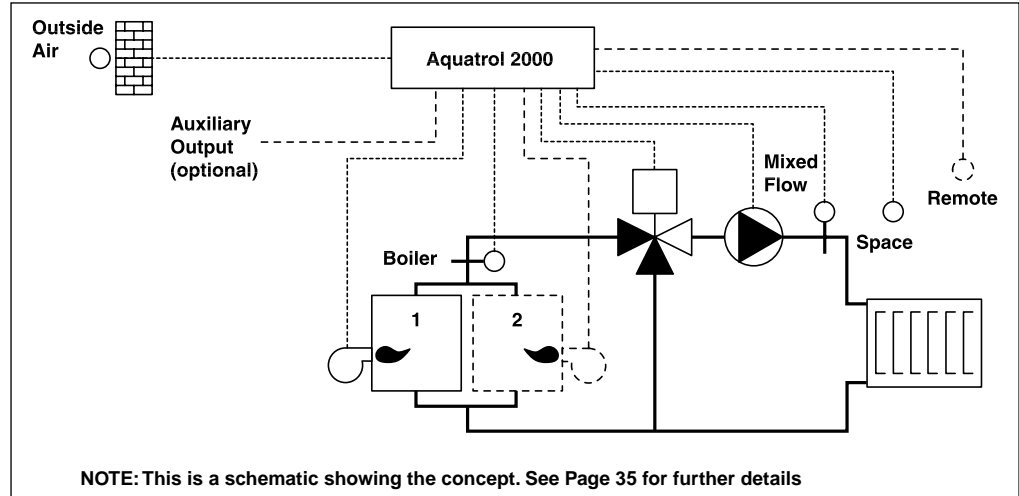

System Selector Switches		Set	Qty	System Components	
S1	Actuator speed	#	1	W6060C1067	Aquatrol 2000 controller
S2	DHWS System type	A	1	T7043E1008	Outside air sensor
S3	DHWS Programme override	A	2*	T7043F1006	Immersion sensor OR
S4	DHWS Priority operation	B	2*	T7044C1002	Strap-on sensor
S5	Number of boilers	#	1	T8102B1027	Space sensor
S6	Type of heating system	A	*Or combination to a total of 2 water sensors		
S7	Compensated heating mode	A	OPTIONS:		
S8	Boiler/mixed flow differential or boiler setpoint selection	#	1	K42007745-005	Wiring centre
# = Set to position 'A' or 'B' to suit the specific application.			1	T8102B1001	Remote unit with setpoint adjustment, manual override switch and extension function
Factory settings shaded grey.					

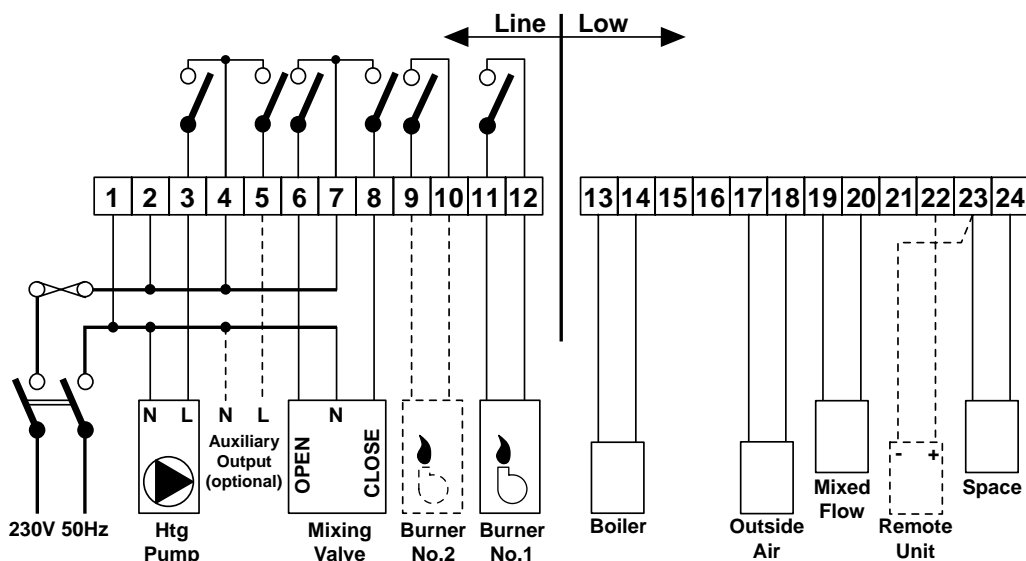

See Page 43 for Burner wiring

See Page 42 for Temperature Sensor wiring

Optimiser, Direct Compensated Boiler(s) and DHWS (priority)

APPLICATION

This plan provides optimum start/stop for the heating plant based on the controller's time programme. The compensated control is directly applied to the boiler. Boiler sequence control maintains optimum heat to the heating and DHWS circuits. The DHWS provides independent, programmable time and temperature control with priority over the demands of the heating circuit.

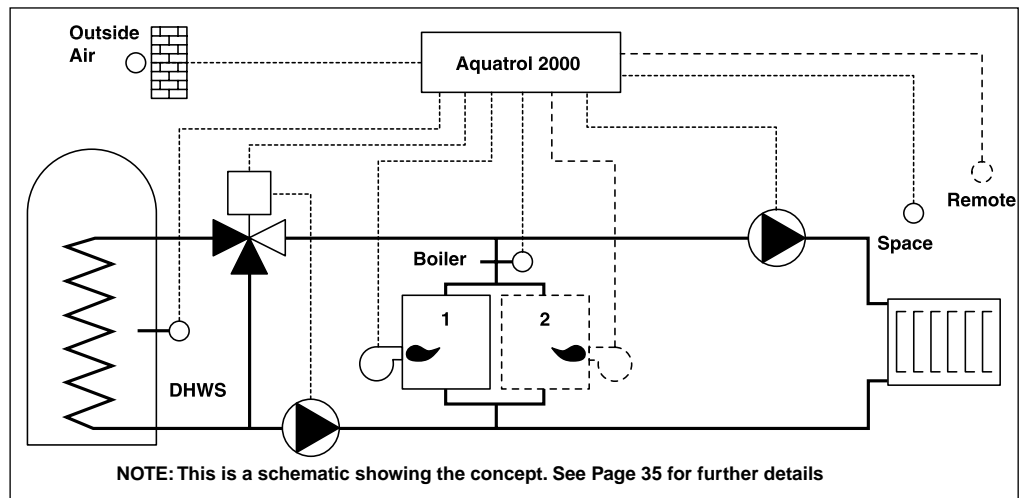

System Selector Switches		Set	Qty	System Components	
S1	Actuator speed	#	1	W6060C1067	Aquatrol 2000 controller
S2	DHWS System type	A	1	T7043E1008	Outside air sensor
S3	DHWS Programme override	A	2*	T7043F1006	Immersion sensor OR
S4	DHWS Priority operation	A	2*	T7044C1002	Strap-on sensor
S5	Number of boilers	#	1	T8102B1027	Space sensor
S6	Type of heating system	A	*Or combination to a total of 2 water sensors		
S7	Compensated heating mode	A	OPTIONS:		
S8	Boiler/mixed flow differential or boiler setpoint selection	#	1	K42007745-005	Wiring centre
# = Set to position 'A' or 'B' to suit the specific application.			1	T8102B1001	Remote unit with setpoint adjustment, manual override switch and extension function
Factory settings shaded grey.					

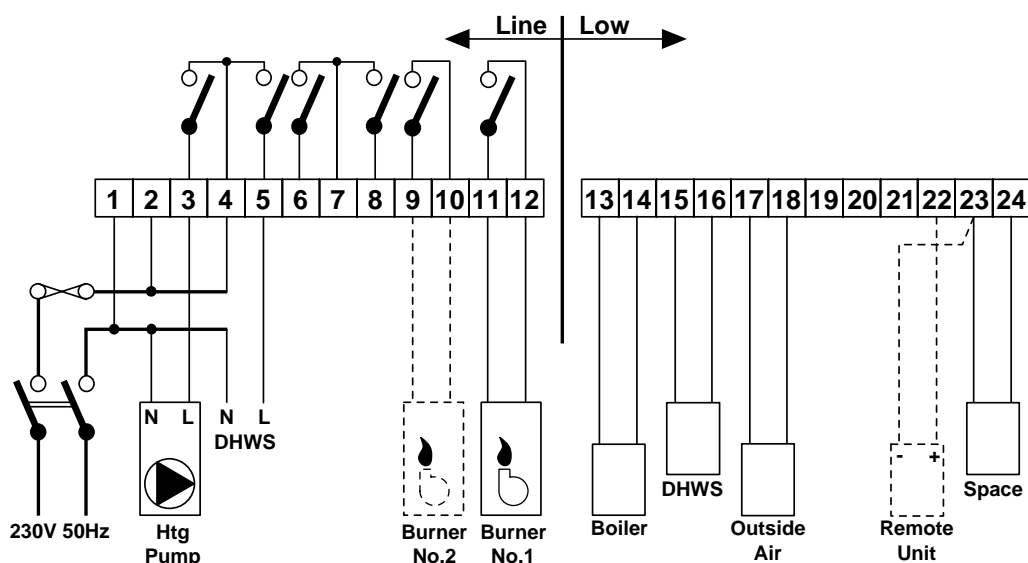

See Page 43 for DHWS and Burner wiring

See Page 42 for Temperature Sensor wiring

Optimiser, Direct Compensated Boiler(s) with Auxiliary Output (optional)

APPLICATION

This plan provides optimum start/stop for the heating plant based on the controller's time programme. The compensated control is directly applied to the boilers. Boiler sequence control maintains optimum heat to the heating circuit. The DHWS output provides independent, programmable time control of an auxiliary electrical load.

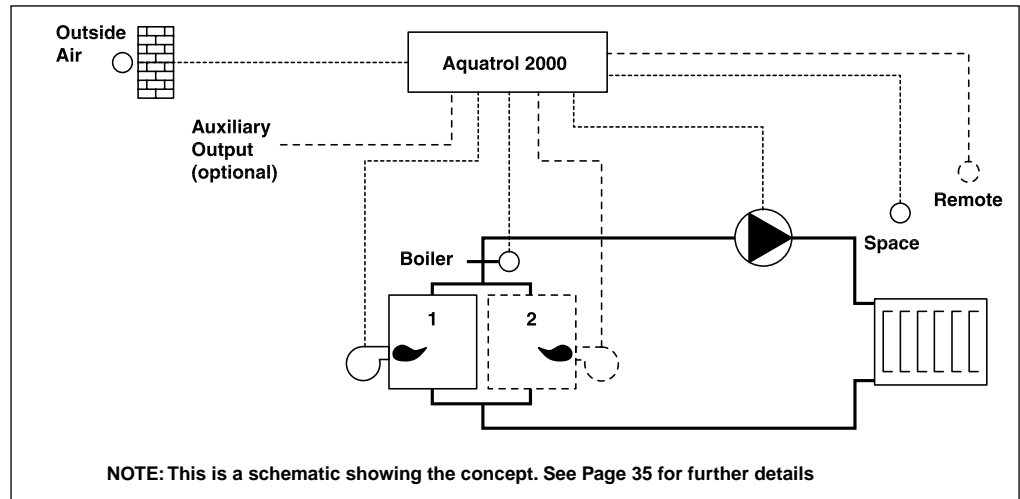

System Selector Switches		Set	Qty	System Components	
S1	Actuator speed	#	1	W6060C1067	Aquatrol 2000 controller
S2	DHWS System type	B	1	T7043E1008	Outside air sensor
S3	DHWS Programme override	A	1*	T7043F1006	Immersion sensor OR
S4	DHWS Priority operation	B	1*	T7044C1002	Strap-on sensor
S5	Number of boilers	#	1	T8102B1027	Space sensor
S6	Type of heating system	A	*Only 1 water sensor		
S7	Compensated heating mode	A	OPTIONS:		
S8	Boiler/mixed flow differential or boiler setpoint selection	#	1	K42007745-005	Wiring centre
# = Set to position 'A' or 'B' to suit the specific application.			1	T8102B1001	Remote unit with setpoint adjustment, manual override switch and extension function
Factory settings shaded grey.					

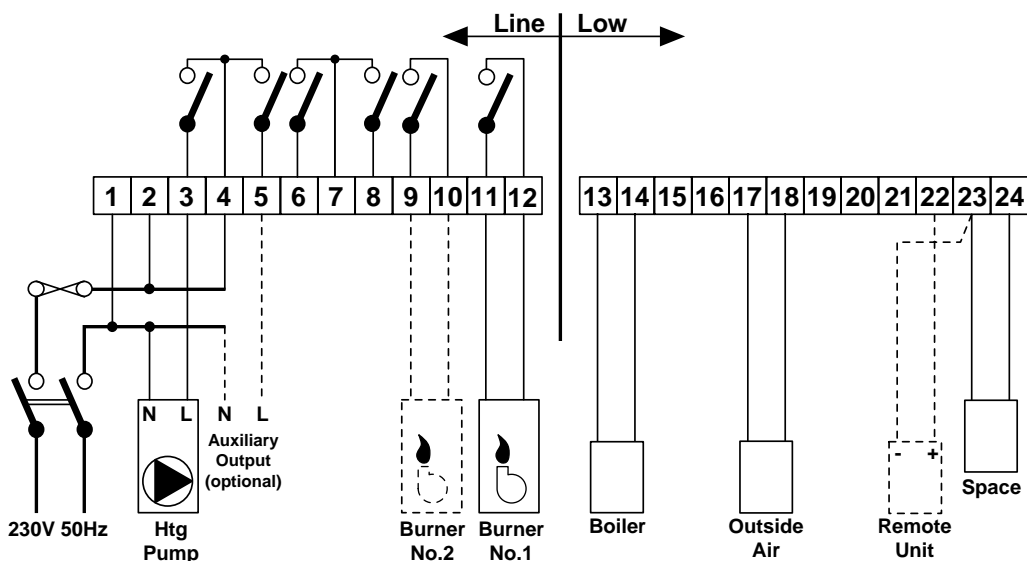

See Page 43 for Burner wiring

See Page 42 for Temperature Sensor wiring

Optimiser only

APPLICATION

This plan provides an optimum start/stop signal based on the controller's time programme. To ensure that the controller functions all year round, the outside air sensor is replaced by a fixed resistor representing a given outside air temperature. No outside air frost protection is provided. No pump overrun occurs at the end of the day.

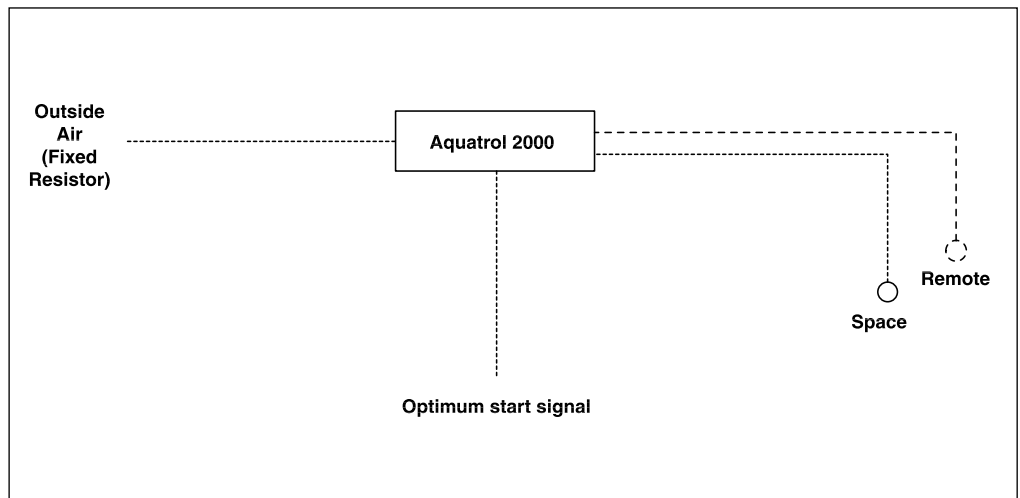

System Selector Switches		Set	Qty	System Components	
S1	Actuator speed	#	1	W6060C1067	Aquatrol 2000 controller
S2	DHWS System type	A	1		Fixed resistor
S3	DHWS Programme override	A			
S4	DHWS Priority operation	B			
S5	Number of boilers	#	1	T8102B1027	Space sensor
S6	Type of heating system	A			
S7	Compensated heating mode	A			
S8	Boiler/mixed flow differential or boiler setpoint selection	#	1	K42007745-005	Wiring centre
# = Set to position 'A' or 'B' to suit the specific application.			1	T8102B1001	Remote unit with setpoint adjustment, manual override switch and extension function
Factory settings shaded grey.					

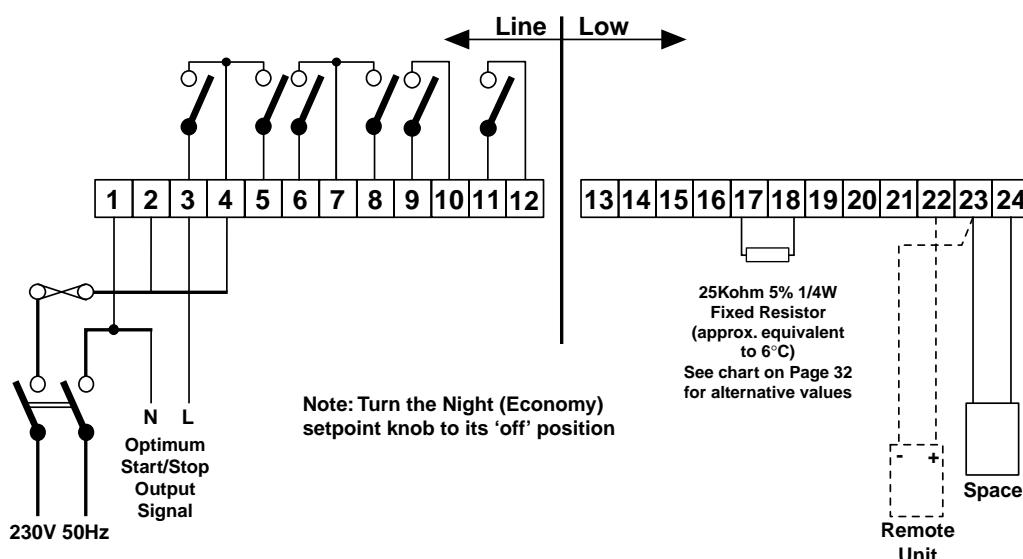

Compensated Heating, Boiler(s) and DHWS (shifting priority)

APPLICATION

This plan provides fixed time start/stop for the heating plant based on the controller's time programme with compensated heating via a mixing valve. Boiler sequence control maintains optimum heat to the heating and DHWS circuits. The DHWS provides independent, programmable time and temperature control with variable priority dependant on demand.

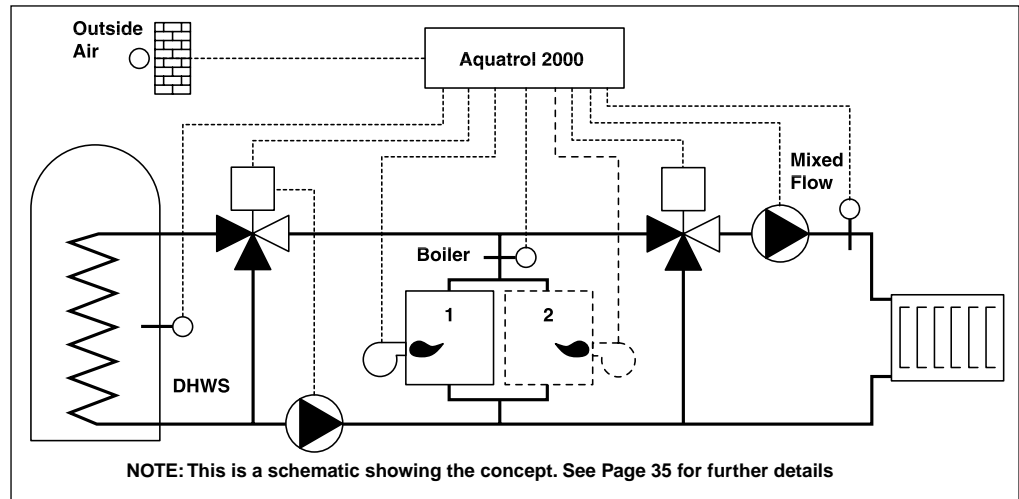

System Selector Switches		Set	Qty	System Components	
S1	Actuator speed	#	1	W6060C1067	Aquatrol 2000 controller
S2	DHWS System type	A	1	T7043E1008	Outside air sensor
S3	DHWS Programme override	A	3*	T7043F1006	Immersion sensor OR
S4	DHWS Priority operation	A	3*	T7044C1002	Strap-on sensor
S5	Number of boilers	#			
S6	Type of heating system	A			*Or combination to a total of 3 water sensors
S7	Compensated heating mode	A			OPTIONS:
S8	Boiler/mixed flow differential or boiler setpoint selection	#	1	K42007745-005	Wiring centre
# = Set to position 'A' or 'B' to suit the specific application.					
Factory settings shaded grey.					

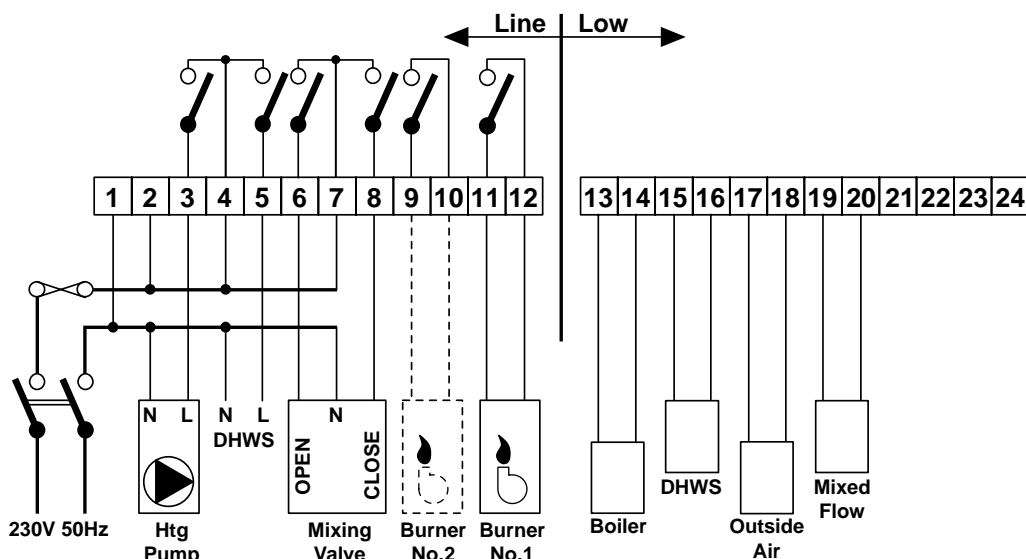

See Page 43 for DHWS and Burner wiring

See Page 42 for Temperature Sensor wiring

Compensated Heating, Boiler(s) and DHWS (parallel operation)

APPLICATION

This plan provides fixed time start/stop for the heating plant based on the controller's time programme with compensated heating via a mixing valve. Boiler sequence control maintains optimum heat to the heating and DHWS circuits. The DHWS provides independent, programmable time and temperature control in parallel with the heating circuit.

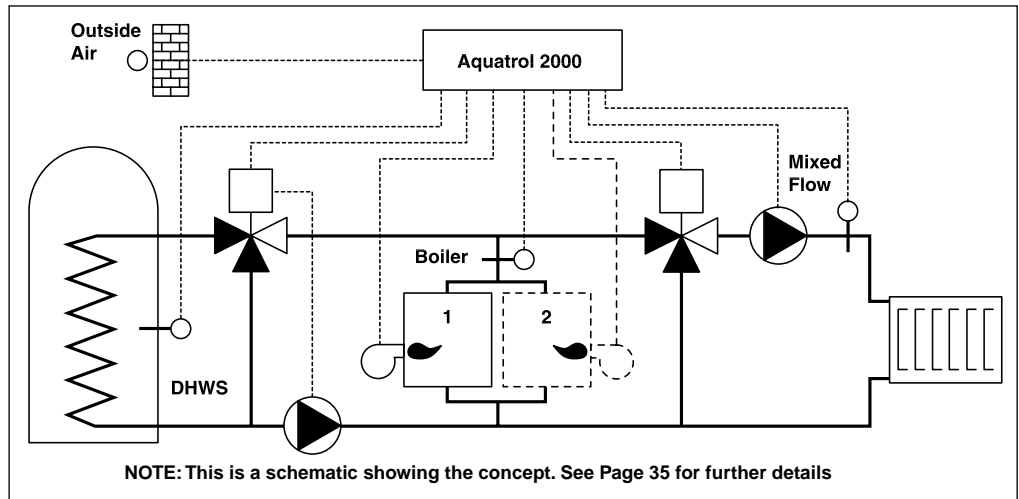

System Selector Switches		Set	Qty	System Components	
S1	Actuator speed	#	1	W6060C1067	Aquatrol 2000 controller
S2	DHWS System type	A	1	T7043E1008	Outside air sensor
S3	DHWS Programme override	A	3*	T7043F1006	Immersion sensor OR
S4	DHWS Priority operation	B	3*	T7044C1002	Strap-on sensor
S5	Number of boilers	#			
S6	Type of heating system	A		*Or combination to a total of 3 water sensors	
S7	Compensated heating mode	A		OPTIONS:	
S8	Boiler/mixed flow differential or boiler setpoint selection	#	1	K42007745-005	Wiring centre
# = Set to position 'A' or 'B' to suit the specific application.					
Factory settings shaded grey.					

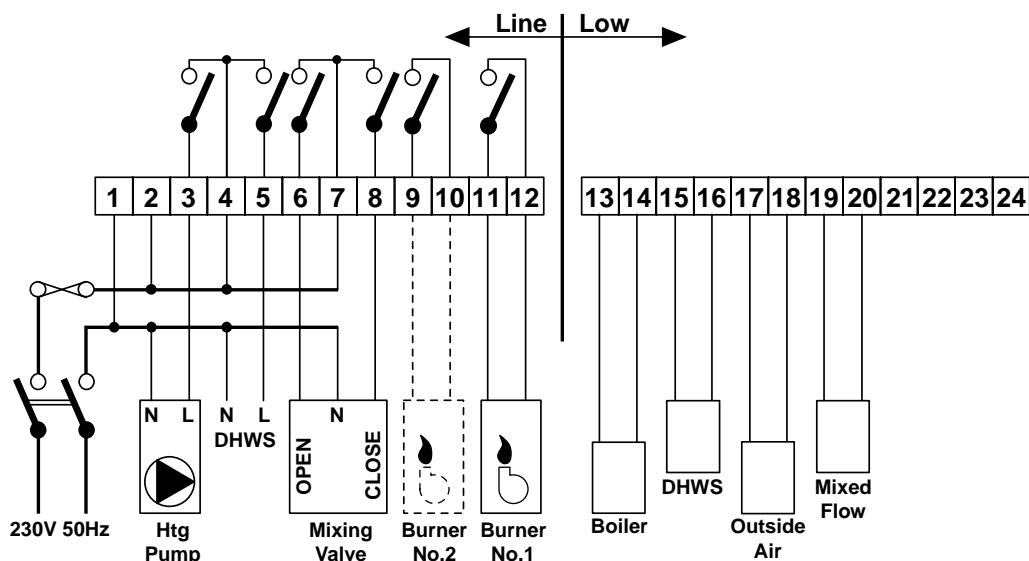

See Page 43 for DHWS and Burner wiring

See Page 42 for Temperature Sensor wiring

Compensated Heating, Boiler(s) and DHWS (separate)

APPLICATION

This plan provides fixed time start/stop for the heating plant based on the controller's time programme with compensated heating via a mixing valve. Boiler sequence control maintains optimum heat to the heating circuit. The DHWS provides independent, programmable time and temperature control separate from the heating boiler(s).

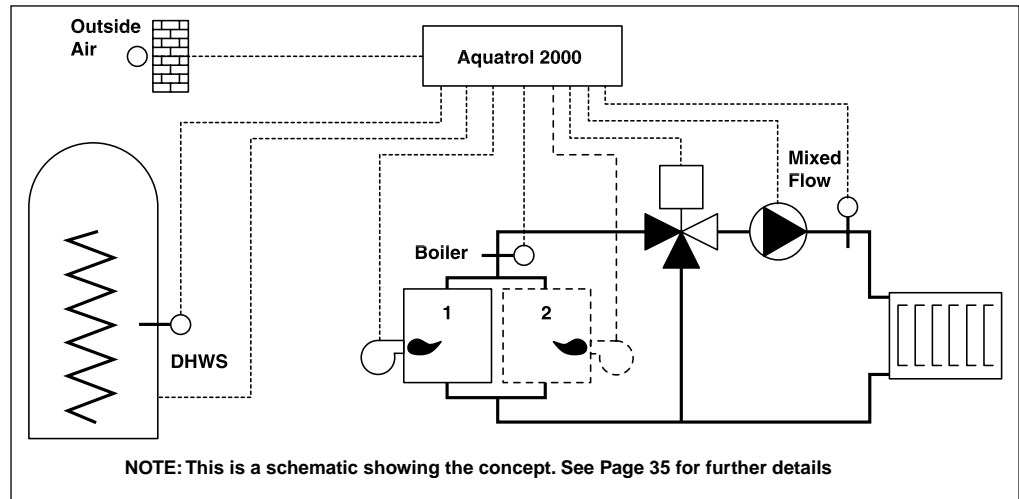

System Selector Switches		Set	Qty	System Components	
S1	Actuator speed	#	1	W6060C1067	Aquatrol 2000 controller
S2	DHWS System type	B	1	T7043E1008	Outside air sensor
S3	DHWS Programme override	A	3*	T7043F1006	Immersion sensor OR
S4	DHWS Priority operation	B	3*	T7044C1002	Strap-on sensor
S5	Number of boilers	#			
S6	Type of heating system	A		*Or combination to a total of 3 water sensors	
S7	Compensated heating mode	A		OPTIONS:	
S8	Boiler/mixed flow differential or boiler setpoint selection	#	1	K42007745-005	Wiring centre
# = Set to position 'A' or 'B' to suit the specific application.					
Factory settings shaded grey.					

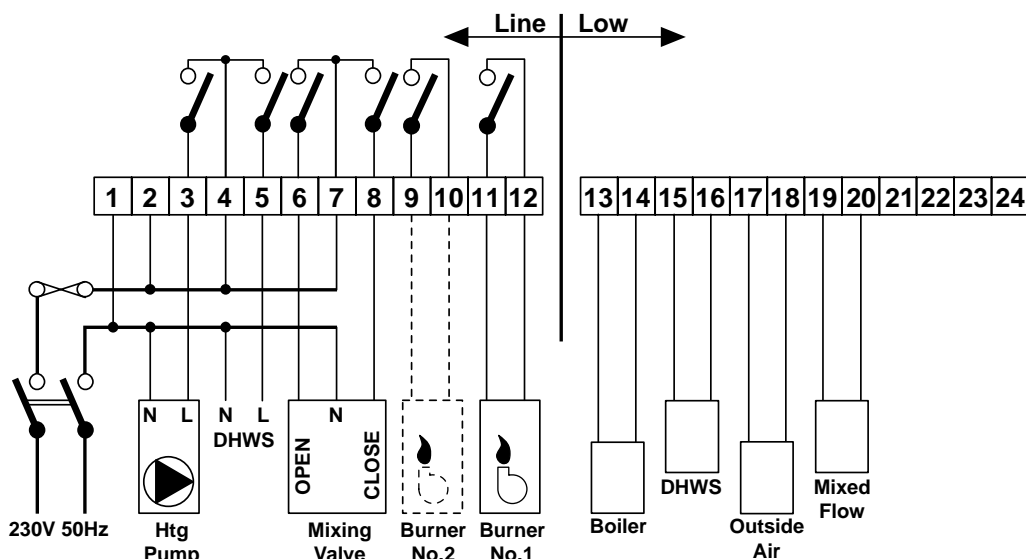

See Page 43 for DHWS and Burner wiring

See Page 42 for Temperature Sensor wiring

Compensated Heating, Boiler(s) with Auxiliary Output (optional)

APPLICATION

This plan provides fixed time start/stop for the heating plant based on the controller's time programme with compensated heating via a mixing valve. Boiler sequence control maintains optimum heat to the heating circuit. The DHWS output provides independent, programmable time control of an auxiliary electrical load.

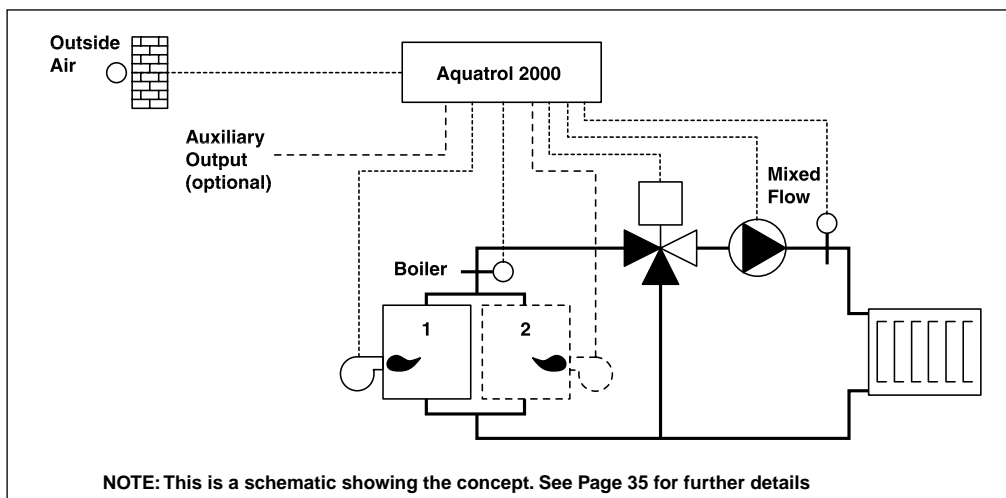

System Selector Switches		Set	Qty	System Components	
S1	Actuator speed	#	1	W6060C1067	Aquatrol 2000 controller
S2	DHWS System type	A	1	T7043E1008	Outside air sensor
S3	DHWS Programme override	A	2*	T7043F1006	Immersion sensor OR
S4	DHWS Priority operation	B	2*	T7044C1002	Strap-on sensor
S5	Number of boilers	#			
S6	Type of heating system	A		*Or combination to a total of 2 water sensors	
S7	Compensated heating mode	A		OPTIONS:	
S8	Boiler/mixed flow differential or boiler setpoint selection	#	1	K42007745-005	Wiring centre
# = Set to position 'A' or 'B' to suit the specific application.					
Factory settings shaded grey.					

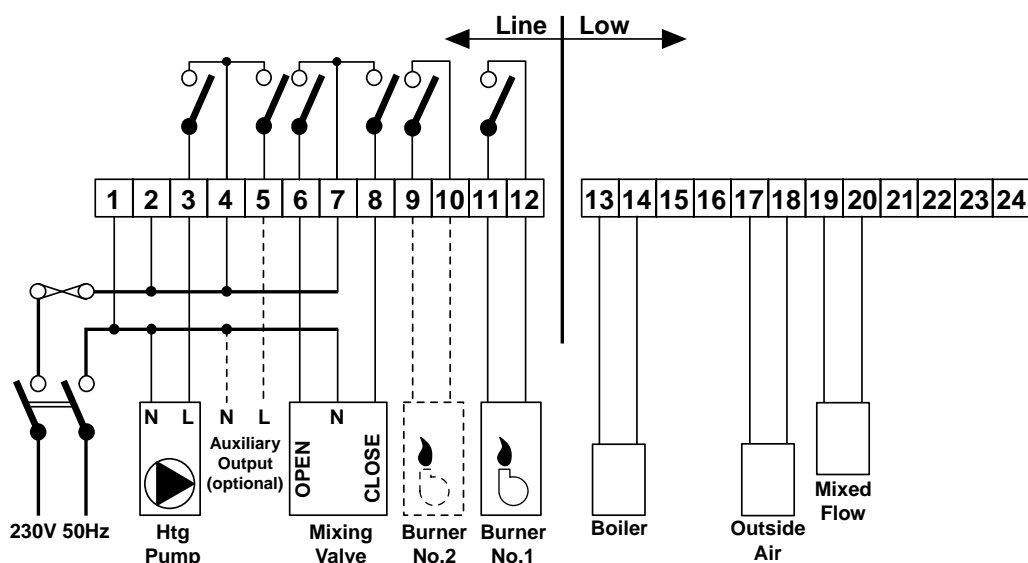

See Page 43 for Burner wiring

See Page 42 for Temperature Sensor wiring

Direct Compensated Boiler(s) and DHWS (priority)

APPLICATION

This plan provides fixed time start/stop for the heating plant based on the controller's time programme. The compensated control is directly applied to the boilers. Boiler sequence control maintains optimum heat to the heating and DHWS circuits. The DHWS provides independent, programmable time and temperature control with priority over the demands of the heating circuit.

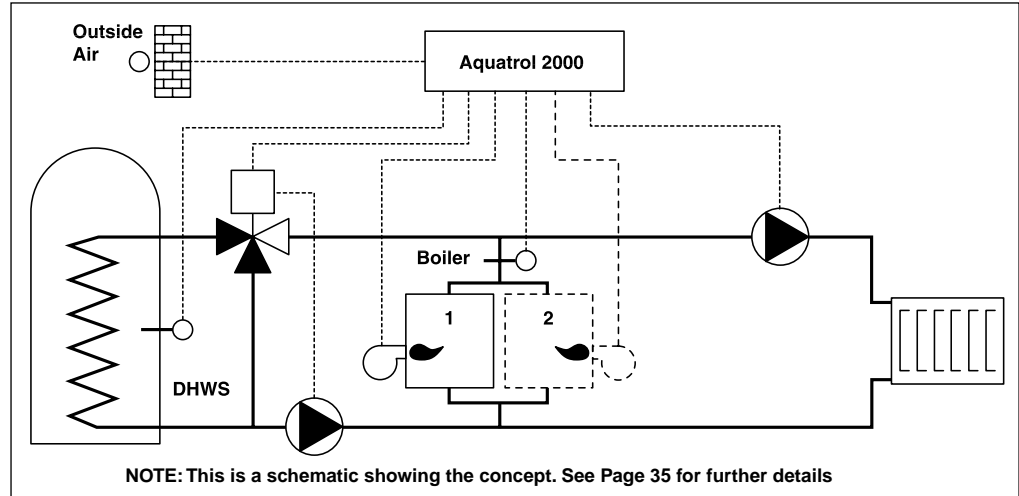

System Selector Switches		Set	Qty	System Components	
S1	Actuator speed	#	1	W6060C1067	Aquatrol 2000 controller
S2	DHWS System type	B	1	T7043E1008	Outside air sensor
S3	DHWS Programme override	A	2*	T7043F1006	Immersion sensor OR
S4	DHWS Priority operation	B	2*	T7044C1002	Strap-on sensor
S5	Number of boilers	#			
S6	Type of heating system	A		*Or combination to a total of 2 water sensors	
S7	Compensated heating mode	A		OPTIONS:	
S8	Boiler/mixed flow differential or boiler setpoint selection	#	1	K42007745-005	Wiring centre
# = Set to position 'A' or 'B' to suit the specific application.					
Factory settings shaded grey.					

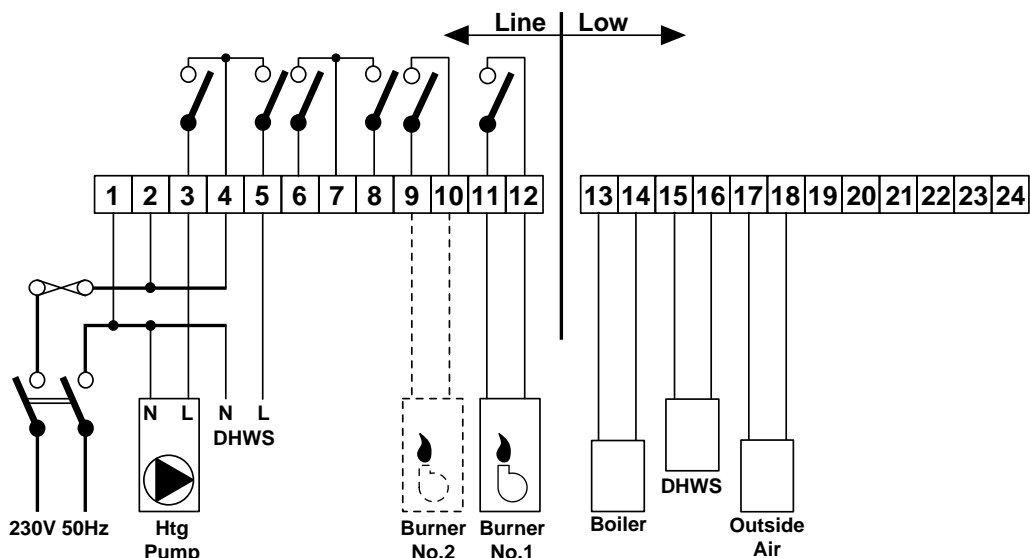

See Page 43 for DHWS and Burner wiring

See Page 42 for Temperature Sensor wiring

Direct Compensated Boiler(s) with Auxiliary Output (optional)

APPLICATION

This plan provides fixed time start/stop for the heating plant based on the controller's time programme. The compensated control is directly applied to the boilers. Boiler sequence control maintains optimum heat to the heating circuit. The DHWS output provides independent, programmable time control of an auxiliary electrical load.

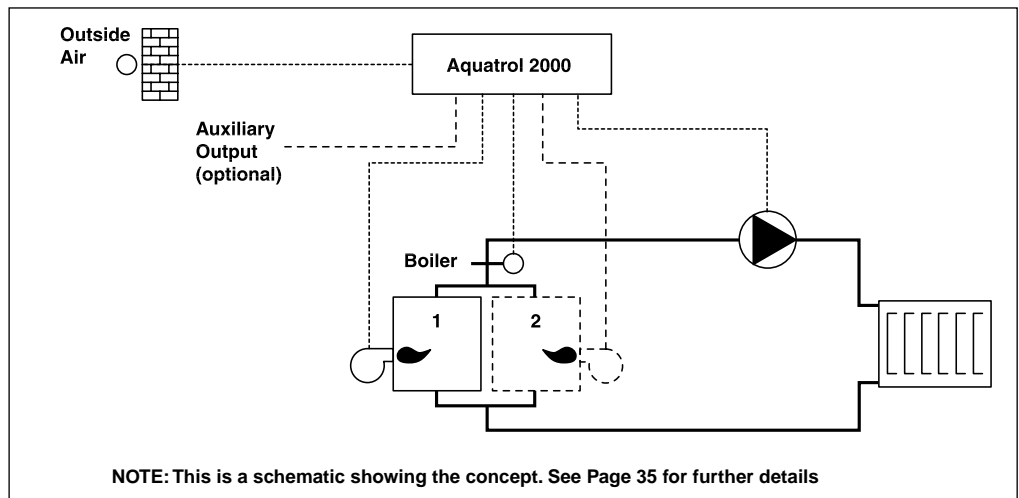

NOTE: This is a schematic showing the concept. See Page 35 for further details

System Selector Switches		Set	Qty	System Components	
S1	Actuator speed	#	1	W6060C1067	Aquatrol 2000 controller
S2	DHWS System type	A	1	T7043E1008	Outside air sensor
S3	DHWS Programme override	A	1*	T7043F1006	Immersion sensor OR
S4	DHWS Priority operation	B	1*	T7044C1002	Strap-on sensor
S5	Number of boilers	#			
S6	Type of heating system	A		*Only 1 water sensor	
S7	Compensated heating mode	A		OPTIONS:	
S8	Boiler/mixed flow differential or boiler setpoint selection	#	1	K42007745-005	Wiring centre
# = Set to position 'A' or 'B' to suit the specific application.					
Factory settings shaded grey.					

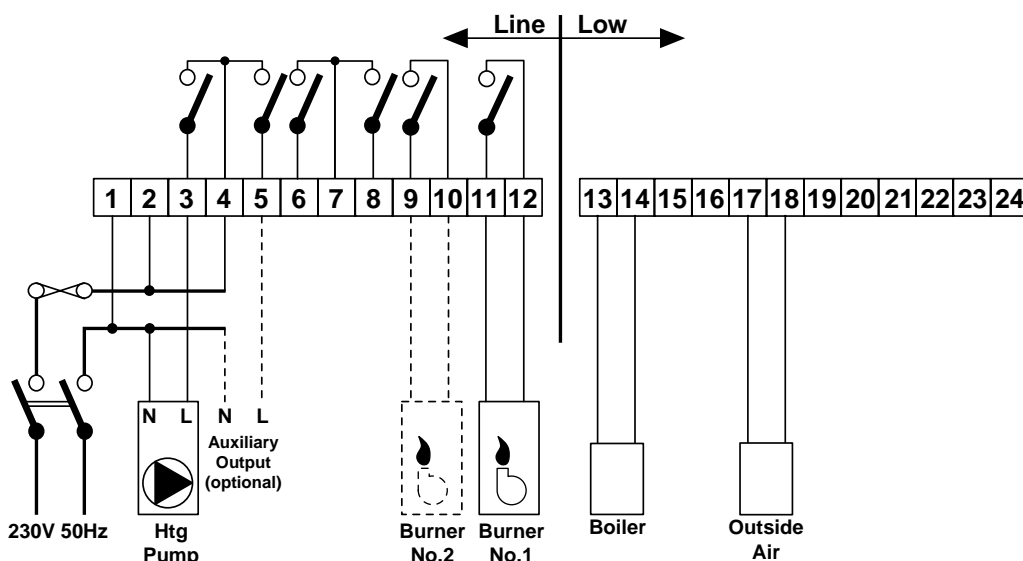

See Page 43 for Burner wiring

See Page 42 for Temperature Sensor wiring

Optimiser, Direct Compensated Boiler(s) and DHWS (separate)

APPLICATION

This plan provides optimum start/stop for the heating plant based on the controller's time programme. The compensated control is directly applied to the boiler(s). Boiler sequence control maintains optimum heat to the heating circuit. The DHWS provides independent, programmable time and temperature control separate from the heating boiler(s).

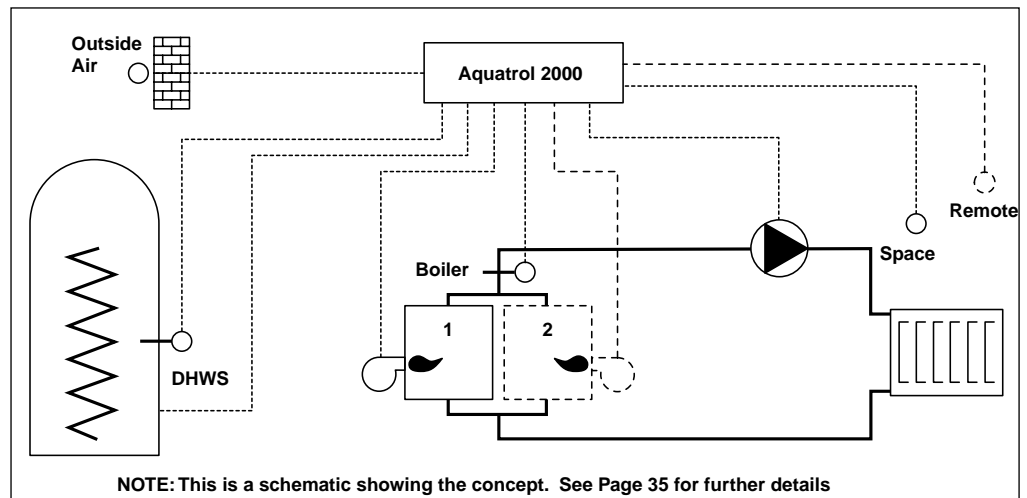

System Selector Switches		Set	Qty	System Components	
S1	Actuator speed	#	1	W6060C1067	Aquatrol 2000 controller
S2	DHWS System type	B	1	T7043E1008	Outside air sensor
S3	DHWS Programme override	A	2*	T7043F1006	Immersion sensor OR
S4	DHWS Priority operation	B	2*	T7044C1002	Strap-on sensor
S5	Number of boilers	#	1	T8102B1027	Space sensor
S6	Type of heating system	A	*Or combination to a total of 2 water sensors		
S7	Compensated heating mode	A	OPTIONS:		
S8	Boiler/mixed flow differential or boiler setpoint selection	#	1	K42007745-005	Wiring centre
# = Set to position 'A' or 'B' to suit the specific application.			1	T8102B1001	Remote unit with setpoint adjustment, manual override switch and extension function.
Factory settings shaded grey.					

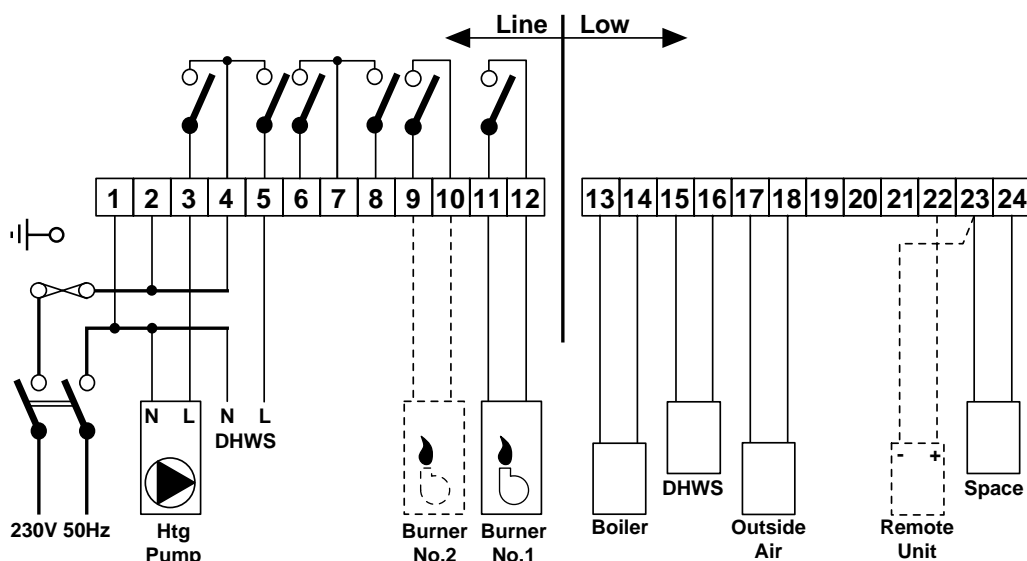

See Page 43 for DHWS and Burner wiring

See Page 42 for Temperature Sensor wiring

Direct Compensated Boiler(s) and DHWS (separate)

APPLICATION

This plan provides fixed time start/stop for the heating plant based on the controller's time programme. The compensated control is directly applied to the boiler(s). Boiler sequence control maintains optimum heat to the heating circuit. The DHWS provides independent, programmable time and temperature control separate from the heating boiler(s).

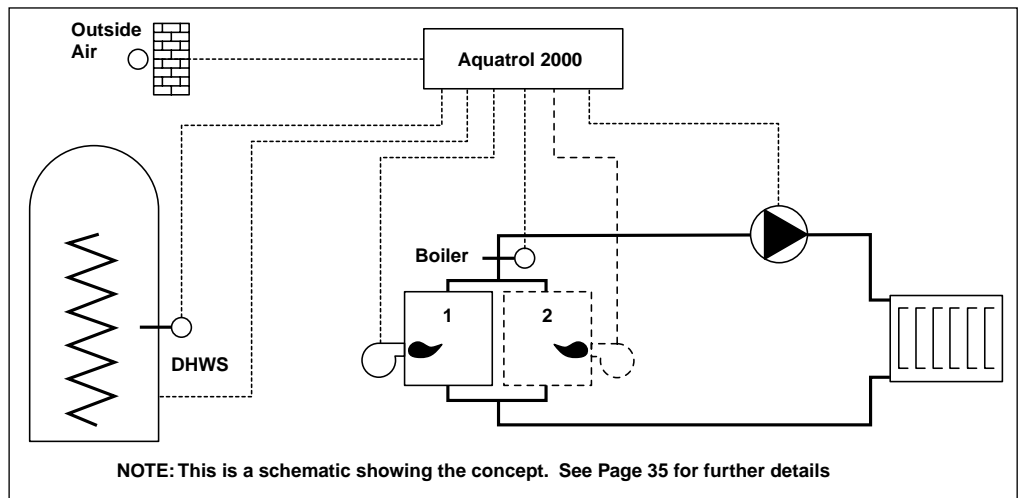

System Selector Switches		Set	Qty	System Components	
S1	Actuator speed	#	1	W6060C1067	Aquatrol 2000 controller
S2	DHWS System type	B	1	T7043E1008	Outside air sensor
S3	DHWS Programme override	A	2*	T7043F1006	Immersion sensor OR
S4	DHWS Priority operation	B	2*	T7044C1002	Strap-on sensor
S5	Number of boilers	#			
S6	Type of heating system	A		*Or combination to a total of 2 water sensors	
S7	Compensated heating mode	A		OPTIONS:	
S8	Boiler/mixed flow differential or boiler setpoint selection	#	1	K42007745-005	Wiring centre
# = Set to position 'A' or 'B' to suit the specific application.					
Factory settings shaded grey.					

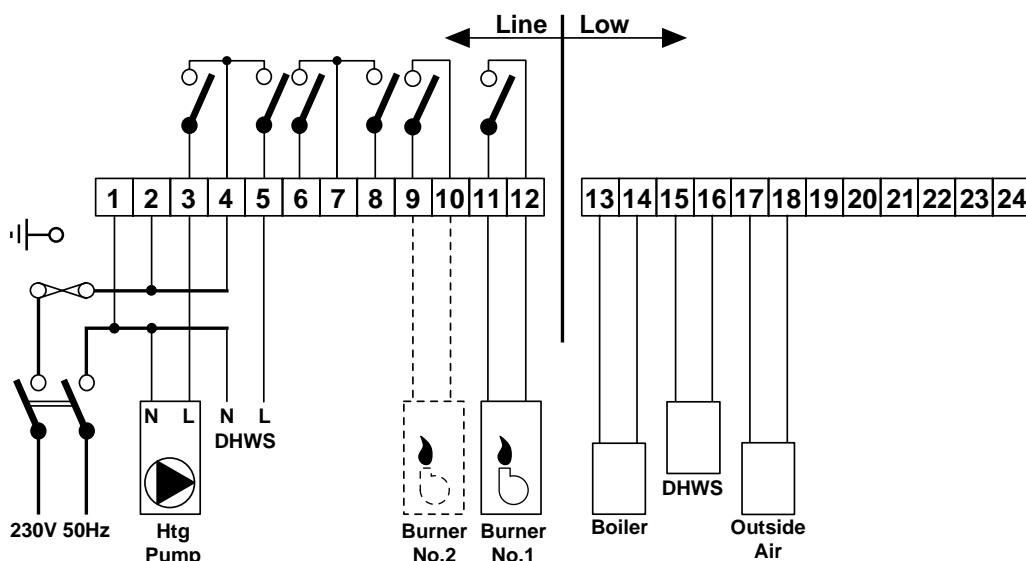

See Page 43 for DHWS and Burner wiring

See Page 42 for Temperature Sensor wiring

Small System - Optimiser, Direct Compensated Boiler(s) and DHWS (priority)

APPLICATION

This plan provides optimum start/stop for the heating plant based on the controller's time programme. The compensated heating control is directly applied to the boiler(s). Boiler sequence control maintains optimum heat to the heating and DHWS circuits. The DHWS provides independent, programmable time and temperature control with priority over the demands of the heating circuit.

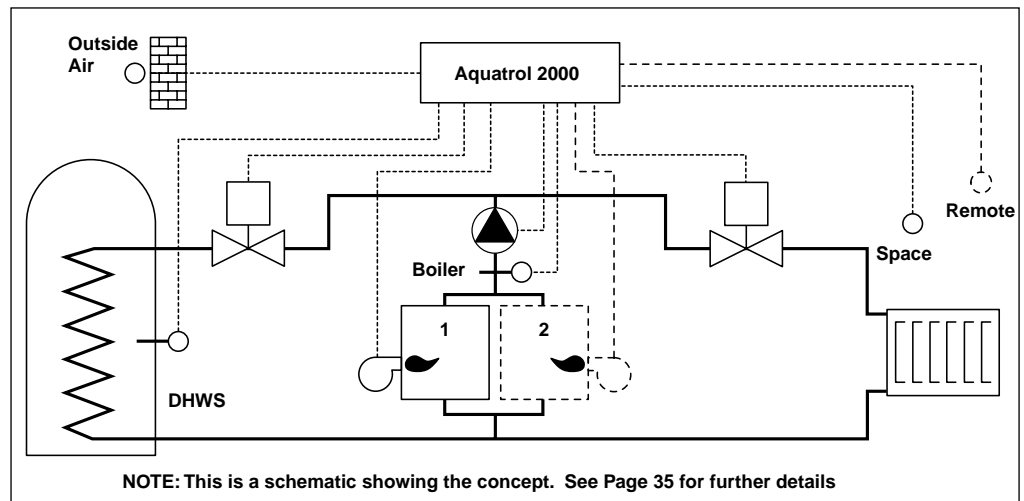

System Selector Switches		Set	Qty	System Components	
S1	Actuator speed	#	1	W6060C1067	Aquatrol 2000 controller
S2	DHWS System type	A	1	T7043E1008	Outside air sensor
S3	DHWS Programme override	A	2*	T7043F1006	Immersion sensor OR
S4	DHWS Priority operation	A	2*	T7044C1002	Strap-on sensor
S5	Number of boilers	#	1	T8102B1027	Space sensor
S6	Type of heating system	A	*Or combination to a total of 2 water sensors		
S7	Compensated heating mode	A	OPTIONS:		
S8	Boiler/mixed flow differential or boiler setpoint selection	#	1	K42007745-005	Wiring centre
# = Set to position 'A' or 'B' to suit the specific application.			1	T8102B1001	Remote unit with setpoint adjustment, manual override switch and extension function.
Factory settings shaded grey.					

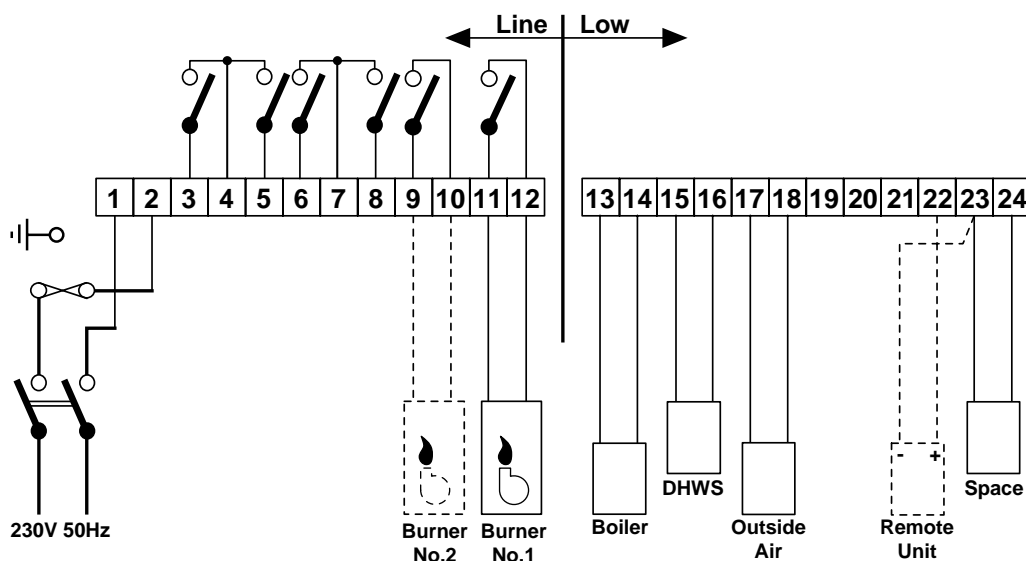

See Page 43/45 for Heating Pump, DHWS and Burner wiring

See Page 42 for Temperature Sensor wiring

Small System - Direct Compensated Boiler(s) and DHWS (priority)

APPLICATION

This plan provides fixed time start/stop for the heating plant based on the controller's time programme. The compensated control is directly applied to the boiler(s). Boiler sequence control maintains optimum heat to the heating circuit and DHWS circuits. The DHWS provides independent, programmable time and temperature control with priority over the demands of the heating circuit.

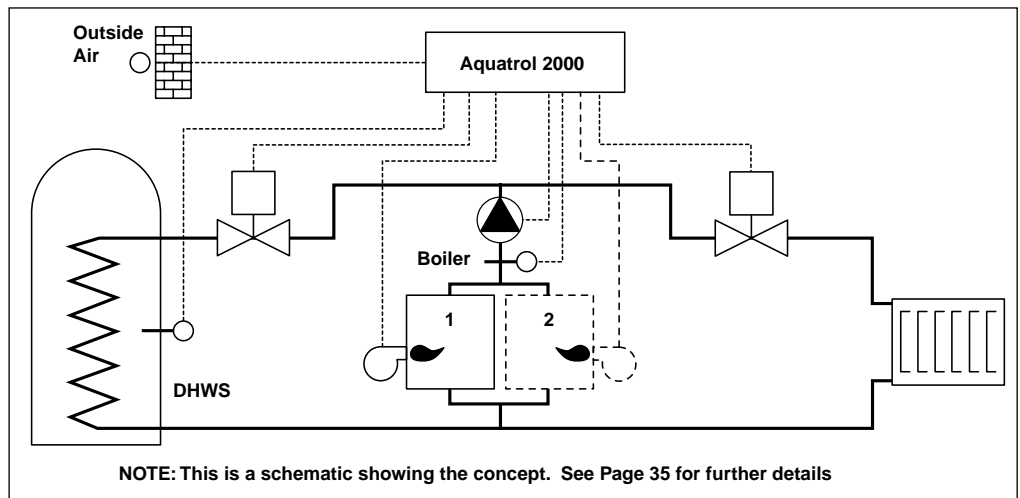

System Selector Switches		Set	Qty	System Components	
S1	Actuator speed	#	1	W6060C1067	Aquatrol 2000 controller
S2	DHWS System type	B	1	T7043E1008	Outside air sensor
S3	DHWS Programme override	A	2*	T7043F1006	Immersion sensor OR
S4	DHWS Priority operation	B	2*	T7044C1002	Strap-on sensor
S5	Number of boilers	#			
S6	Type of heating system	A		*Or combination to a total of 2 water sensors	
S7	Compensated heating mode	A		OPTIONS:	
S8	Boiler/mixed flow differential or boiler setpoint selection	#	1	K42007745-005	Wiring centre
# = Set to position 'A' or 'B' to suit the specific application.					
Factory settings shaded grey.					

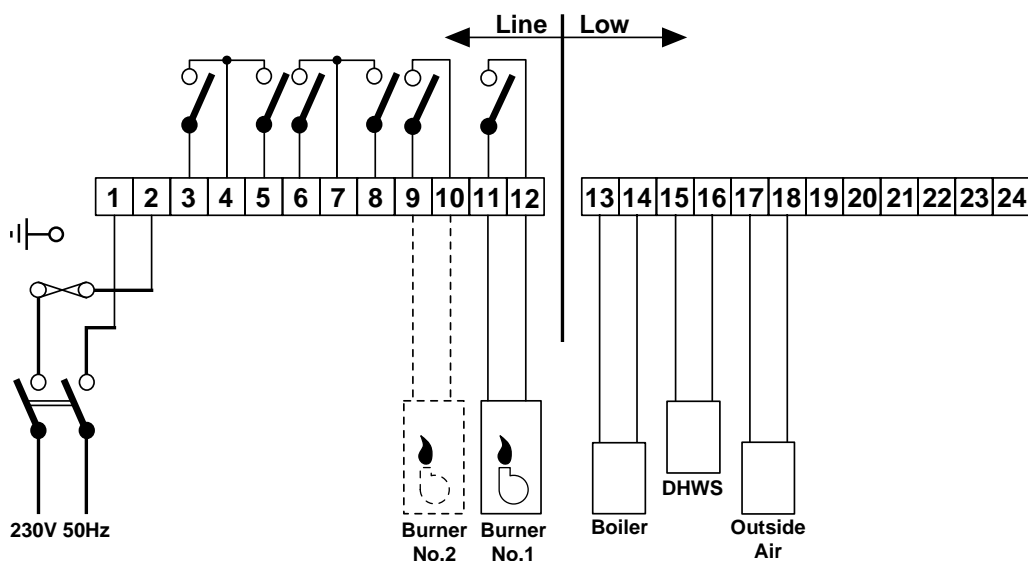

See Page 43/45 for Heating Pump, DHWS and Burner wiring

See Page 42 for Temperature Sensor wiring

Notes

Mechanical Installation Notes

These notes are only intended as hints to ensure a correct first time installation. The best sources for full technical assistance and guidance would be a mechanical engineering consultant or the boiler manufacturer.

In modern, high efficiency boilers it is important to maintain an adequate flow of water through the boiler(s) under all operating conditions to maintain maximum efficiency, prevent excessive stress on the boiler which may lead to premature failure and to

remove residual heat. The use of variable and constant temperature circuits with mixing/diverting valves creates a situation where the flow through the boiler(s) is reduced.

In many instances 3-port motorised valves have been installed on the return to create a primary loop which would always allow circulation through the 'on-line' boiler(s). This method cannot be used with this controller since the boiler output signal is time and temperature controlled.

PRIMARY LOOP SYSTEMS

To overcome these problems, the primary loop header is one simple method for multiple and single boiler installations. It provides a constant flow through the boiler(s) and should be sized to achieve a temperature difference across the boiler load equal to the system design temperature drop.

The primary loop header comes into its own on existing boiler installations where the boiler(s) are replaced by high efficiency boilers; typically with higher resistances.

The primary pump is sized to overcome the boiler resistance and should negate the need to uprate the existing system pump(s). See page 43 for suggested wiring diagram.

When designing systems with multiple boilers or secondary circuits it is important to ensure that the system is hydraulically balanced on the boiler circuit as well as the secondary circuits.

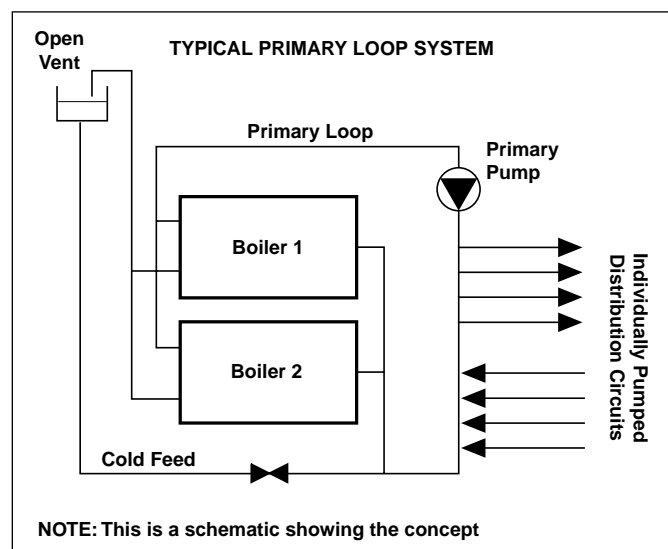

REVERSE RETURN CONNECTION

In simple multiple boiler installations where the boilers offer similar resistances, the water flow through each boiler can often be balanced by using a reverse return connection method as shown in the diagram right.

Where it is impossible to incorporate a reverse return connection or where the boilers have different hydraulic resistances, e.g. condensing boilers installed with conventional, boilers on the same circuit, then regulating valves must be installed to enable the water circuits to be effectively balanced.

Care should also be taken when sizing the pump(s) and it should not necessarily be assumed that existing pump(s) will be adequately sized. In many cases a higher system resistance will be encountered requiring the pump(s) to be uprated to suit.

Balancing the secondary circuit(s) is just as important as balancing the primary circuit to ensure that one circuit is not starving another. In primary circuits it is important to ensure that the secondary circuit flow rate does not exceed the capability of the primary pump otherwise reverse flow will occur effectively diluting the flow temperature with cooler return water. In certain condensing boiler installations this may be a design feature.

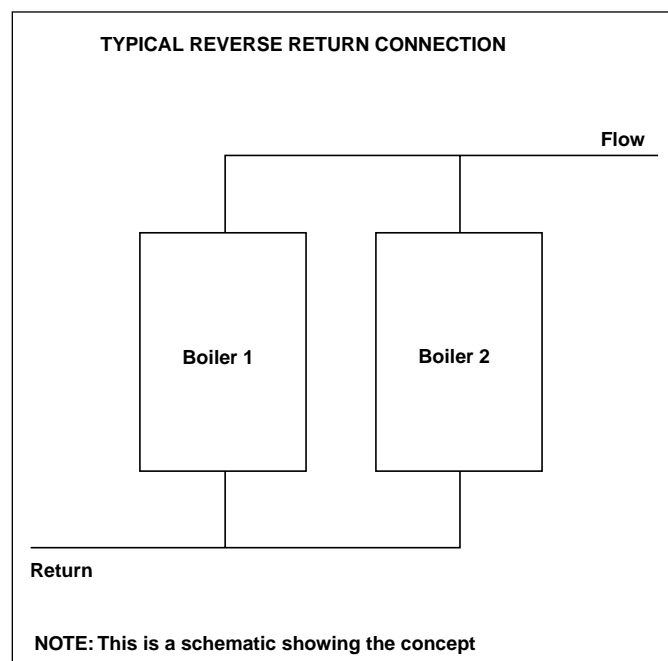

Sensors

AUTOMATIC SENSOR RECOGNITION

One of the major features of the Aquatrol 2000 is its ability to recognise which temperature sensors are connected. This feature enables the controller to automatically self-configure on initial power up to match the application to be controlled.



T8102B1027 SPACE SENSOR

The space temperature sensor should be mounted approximately 1.5m above floor level in a good air circulation and well away from any external or internal heat sources, e.g. direct sunlight, radiators, office equipment, etc.

Backplate for square or round conduit boxes plus an escutcheon plate provided as standard.

Sensor: NTC type 10K Ω @ 25°C.

Housing: White.

Weight: 70g.

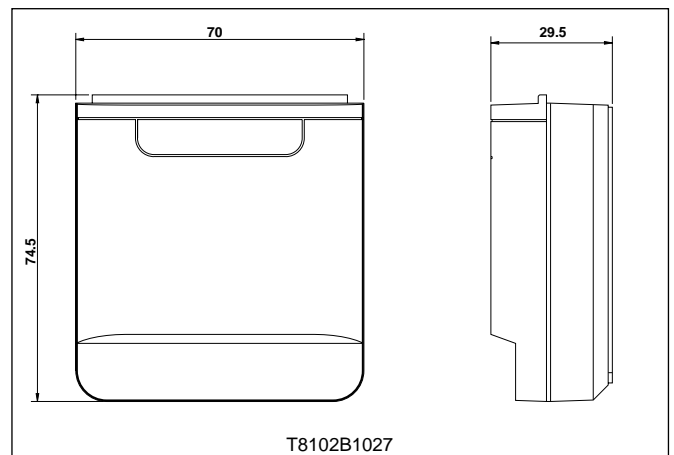

T8102B1027

T8102B1001 REMOTE UNIT

The remote unit incorporates a space temperature sensor, a remote setpoint adjustment knob with adjustable range stops, a 3 hour extension push button with LED indication, and a manual switch to override the operating mode. The day or night flag will flash on the controller when the mode is overridden. When used as a space temperature sensor, the same mounting directions for the space temperature sensor apply.

This unit is polarity sensitive and the correct connection format must be observed. Failure to observe the correct polarity will cause the controller to appear totally defective.

Backplate for square or round conduit boxes plus an escutcheon plate are provided as standard.

If the extension push button is pressed whilst in comfort mode the 3 hour extension is added to the end of that comfort period. If pressed during economy mode, 3 hours of comfort operation starts immediately. Pressing the push button again cancels the 3 hour comfort extension. The DHWS is not affected.

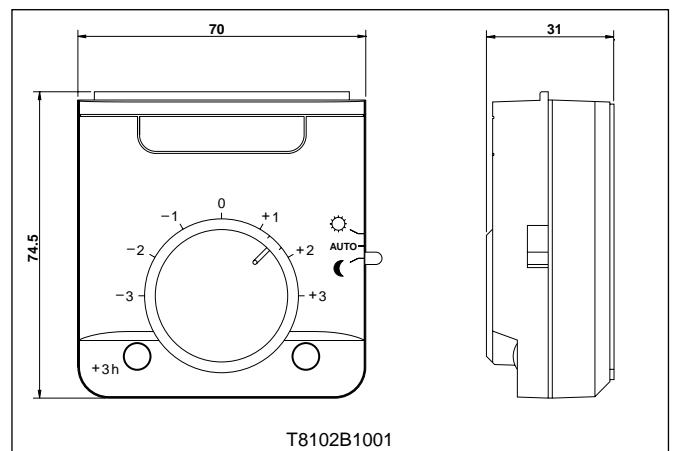

T8102B1001

Sensor: NTC type 10K Ω @ 25°C.

Housing: White.

Weight: 70g.

SPACE SENSOR AND REMOTE UNIT COMBINATIONS

The diagrams right show that it is possible to have a minimum, intermediate or maximum flexibility by using these units in combination.

In applications requiring space temperature measurement the space temperature is taken from either the space sensor or the remote unit. If both the space sensor and the remote unit are connected the temperature measurement is taken from the space temperature sensor. This enables the adjustments-free space temperature sensor to be mounted in a public area whilst still providing a local override facility in a convenient location where unauthorised adjustment is restricted.

If no space temperature measurement is included, the controller assumes that the automatic self-adaptive features are not required. The controller will automatically assume that 'fixed' compensation is required.

IMPORTANT

Do not mount either the space sensor or the remote unit in a room with thermostatic radiator valves fitted to the radiators. If thermostatic radiator valves are already fitted, lock them at their maximum setting.

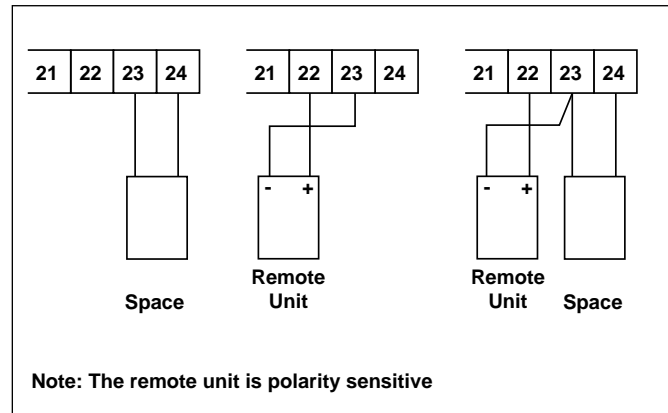

T7043F1006 IMMERSION PIPE OR T7044C1002 CLAMP-ON SENSORS

Depending on the installation, either of these two temperature sensors are suitable for use as either the mixed flow, DHWS or boiler temperature sensor.

When used as the mixed flow temperature sensor, it must be positioned **at least** 10 pipe diameters **after** the heating pump. If the heating pump is in the return pipe, position the temperature sensor at least 1.5m after the 3-port mixing valve, but before the radiators. Failure to observe these distances could cause the control system to cycle rapidly.

In the case of the immersion sensor, the favoured position is on a pipe bend. A $\frac{1}{2}$ " bsp immersion pocket is provided with the unit. Insert the full length of the pocket (100mm) as the sensor, which is on the tip of the stem, needs to be surrounded by the water temperature to be measured.

In the case of the clamp-on sensor it is important to ensure that good heat transfer takes place through the pipe onto the sensitive area. The pipe or cylinder must be cleaned to reveal bright metal. When fitting, cut the clamp-on strip to the approximate length beforehand and tighten the sensor firmly in place using the lock. To further improve heat transfer it is strongly recommended that a heat-conductive compound is used and that the sensor is fully insulated.

Sensor: NTC type 10K Ω @ 25°C.

Housing: Grey.

Weight: 70g (T7044C1002) and 175g (T7043F1006).

Working temperature range: 20 to 115°C.

Maximum ambient temperature: 60°C.

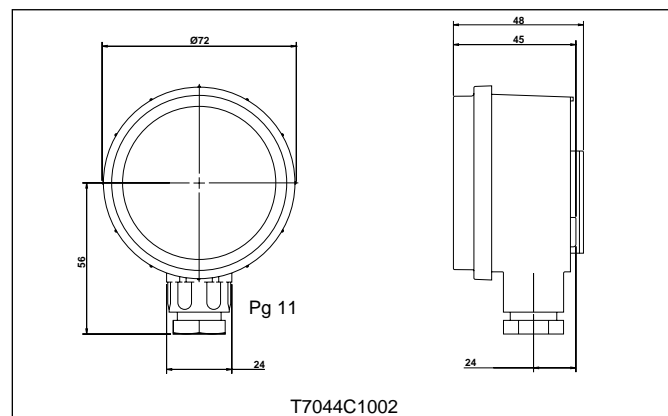
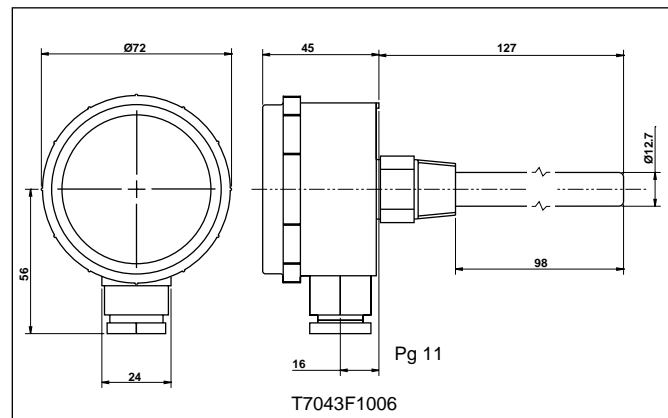

If the mixed flow temperature sensor is not connected, the controller assumes that the compensation effect will be directed to the firing rate of the boiler(s). By connecting the mixed flow temperature sensor, the controller assumes that compensation is required and that a 3-port mixing valve is installed.

If the DHWS temperature sensor is not connected, the controller assumes that there are no hot water demands on the boiler(s). By connecting the DHWS temperature sensor, the controller assumes that an allowance must be made to raise the boiler water temperature to meet the domestic hot water demand.

When connecting the DHWS sensor it is necessary to observe the correct positioning of System Selector Switch, S2. If position 'A' is selected the controller knows that the DHWS demand will be met by the boilers providing the hot water for the radiator circuit. If position 'B' is selected the controller knows that the DHWS heat load is being met by an alternative heat source. With this latter combination of the System Selector Switch and DHWS sensor, the DHWS can still be operated on a time and temperature basis.

T7043E1008 OUTSIDE AIR SENSOR

The outside air temperature sensor should be exposed to the same conditions of temperature, wind and sun as the rooms being controlled. Normally, a north facing wall provides the coldest location and is not affected by direct sunlight. Many buildings do not have a perfect geographic orientation and in these cases choose a north to north-westerly aspect.

Only if all the rooms in the zone to be controlled are facing in one direction should the outside air temperature sensor be mounted on this particular wall.

Do not mount the outside air temperature sensor near windows, doors, exhaust air vents, on external boiler flues, or anywhere that might cause the sensor to give an incorrect measurement.

For small buildings (up to 3 storeys) mount the sensor about 2/3 wall height and, for taller buildings, between the 2nd and 3rd floors.

Sensor: NTC type 10K Ω @ 25°C.

Housing: Grey.

Weight: 70g.

Working temperature range: -30 to +40°C.

Maximum ambient temperature: 60°C.

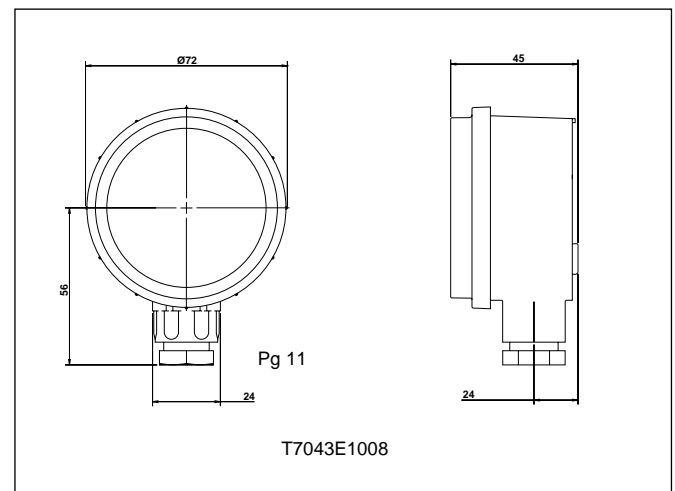

CONDUIT ADAPTER

Electrical installations using 20mm conduit with the T7043F (immersion), T7044C (clamp-on), and T7043E (outside air) sensors will require PG11 conduit adapters. A PG11 (male) to M20 (female) conduit adapter in black plastic may be obtained from Radio Spares; their reference 562-233.

W6060C AQUATROL 2000

The controller is supplied by the factory with the standard base.

This base is perfectly adequate when mounting the controller in a control panel. If the controller is to be mounted through the control panel door, the panel mounting kit is supplied, as standard, with the controller.

When mounting through the control panel door make use of the tagging (security) feature to prevent unauthorised adjustment of the controller. Control panel cut-out dimensions are 138mm wide by 92mm high.

Remember to power the controller from a source that is not interlocked with the control panel isolator. It is impossible to test out the controller operation without power and it is dangerous to circumvent any of the electrical safety devices.

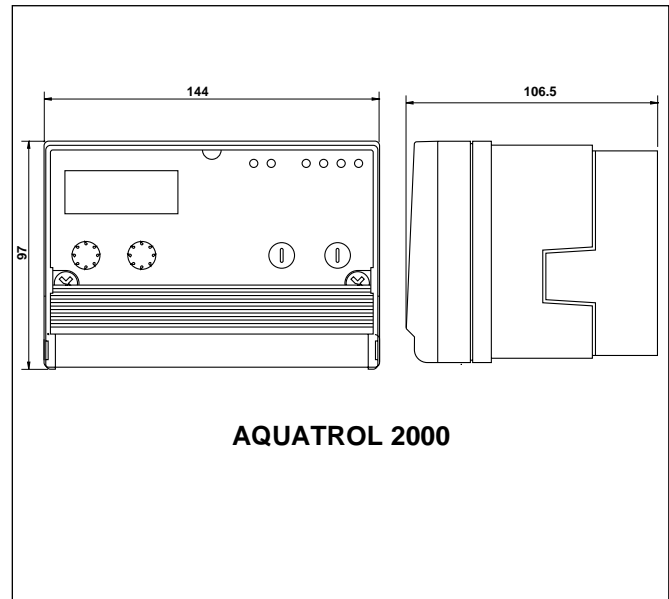

K42007745-005 WIRING CENTRE

The wiring centre is an essential component when mounting the controller on a wall. It provides a number of conduit entries through the bottom, back and sides. In addition, it provides extra terminals to link multiple incoming cables such as line, neutral and earth.

The earth terminals are particularly important for terminating the screened sensor wiring. Many years experience has shown that nearly all problems have their roots in poor or incorrect electrical installation, with specific emphasis on a good, continuous earth. To ensure a 'first time' installation every time, it is recommended that the installer reads the notes on page 35 which cover the electrical installation requirements very thoroughly.

The unit is supplied with the standard base which is ideally suited for control panel installation. To obtain the Wiring Centre order part number K42007745-005 separately.

Seventeen 19mm conduit entries are provided in the wiring compartment, 9 in the bottom, 3 in the right hand side, 1 in the left hand side and 4 in the back.

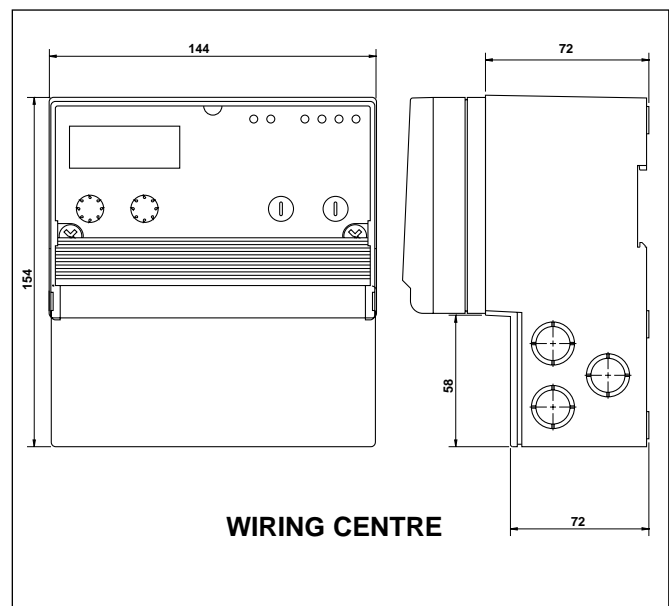

Temperature Sensor Characteristic

Temperature - Resistance Values							
°C	KΩ	°C	KΩ	°C	KΩ	°C	KΩ
-40	333.6	8	21.92	56	2.878	104	0.0650
-39	315.0	9	20.88	57	2.774	105	0.5880
-38	295.0	10	19.90	58	2.674	106	0.5714
-37	276.4	11	18.97	59	2.580	107	0.5556
-36	259.0	12	18.09	60	2.488	108	0.5402
-35	242.8	13	17.26	61	2.400	109	0.5252
-34	227.8	14	16.46	62	2.316	110	0.5108
-33	213.8	15	15.71	63	2.234	111	0.4968
-32	200.6	16	15.00	64	2.158	112	0.4832
-31	188.4	17	14.32	65	2.082	113	0.4702
-30	177.0	18	13.68	66	2.012	114	0.4574
-29	166.4	19	13.07	67	1.942	115	0.4452
-28	156.5	20	12.49	68	1.876	116	0.4334
-27	147.2	21	11.94	69	1.813	117	0.4218
-26	138.5	22	11.42	70	1.751	118	0.4106
-25	130.4	23	10.92	71	1.693	119	0.3998
-24	122.9	24	10.45	72	1.637	120	0.3894
-23	115.8	25	10.00	73	1.582	121	0.3792
-22	109.1	26	9.574	74	1.530	122	0.3694
-21	102.9	27	9.166	75	1.480	123	0.3598
-20	97.12	28	8.778	76	1.432	124	0.3506
-19	91.66	29	8.408	77	1.385	125	0.3416
-18	86.54	30	8.058	78	1.341	126	0.3328
-17	81.72	31	7.722	79	1.298	127	0.3244
-16	77.22	32	7.404	80	1.256	128	0.3162
-15	72.98	33	7.098	81	1.216	129	0.3082
-14	69.00	34	6.808	82	1.178	130	0.3006
-13	65.26	35	6.532	83	1.141	131	0.2930
-12	61.76	36	6.268	84	1.105	132	0.2858
-11	58.46	37	6.016	85	1.071	133	0.2788
-10	55.34	38	5.776	86	1.038	134	0.2720
-9	52.42	39	5.546	87	1.006	135	0.2652
-8	49.66	40	5.326	88	0.975	136	0.2588
-7	47.08	41	5.118	89	0.9452	137	0.2526
-6	44.64	42	4.918	90	0.9164	138	0.2464
-5	42.34	43	4.726	91	0.8888	139	0.2406
-4	40.16	44	4.544	92	0.8620	140	0.2348
-3	38.12	45	4.368	93	0.8364	141	0.2292
-2	36.20	46	4.202	94	0.8114	142	0.2238
-1	34.38	47	4.042	95	0.7874	143	0.2184
0	32.66	48	3.888	96	0.7642	144	0.2134
1	31.04	49	3.742	97	0.7418	145	0.2084
2	29.50	50	3.602	98	0.7202	146	0.2036
3	28.06	51	3.468	99	0.6994	147	0.1988
4	26.68	52	3.340	100	0.6792	148	0.1942
5	25.40	53	3.216	101	0.6596	149	0.1897
6	24.18	54	3.098	102	0.6408	150	0.1854
7	23.02	55	2.986	103	0.6213		

Electrical Installation Requirements

SENSOR WIRING

The rule for wiring any sensor is, **if in doubt use screened cables**. It is important to reduce the incidence for electrical noise interference to occur. To meet this requirement always use screened cables and **always run the sensor wiring separately from any other medium to high voltage cables**. The electrical installation should comply in all respects with the requirements of the latest edition of the IEE Regulations with respect to mixing cables of different voltages as well as the recommended minimum distances between cables carrying different voltages.

The maximum wiring length between any field-mounted device and the Aquatrol 2000 is 100m. The exception is the connection to the remote unit which is effectively a data communications link and is, therefore, also polarity sensitive. The maximum distance between the remote unit and the Aquatrol 2000 controller is 50m. Failure to observe the correct polarity will cause the controller to **appear totally** defective. The terminals inside each sensor can accommodate conductors with a maximum cross sectional area of 1.5mm². The ability to connect conduit via a Pg11 conduit fitting is provided.

The recommended cable for sensor wiring is any **screened, twisted pair or**, for fire-risk areas such as boiler houses, **Pirelli FP200**. MICC cables should **not** be used since this type of cable does not employ a twist and the screen, if not correctly earthed, can make the installation subject to earth loops and associated electrical noise.

In all cases, the **screen must be continuous** from the sensor to the Aquatrol 2000 controller and **only earthed at the controller end**.

On no account should multi-core cables be used. Suitable twin core, plastic covered, twisted, screened cables can be obtained from:

Radio Spares	368-671
Alpha	5471
Beldon	9501
UL	2464

For wall mounted installations it is recommended that the wiring centre (part number K42007745-005) is used instead of the standard base since it has additional terminals for earthing and conduit knock-outs.

To ensure the sensor screens are effectively earthed, the power supply to the Aquatrol 2000 should be **effectively earthed directly to the building's consumer unit**. Attaching a short length of earth wire to a convenient copper water pipe is no guarantee that an effective earth connection will be achieved.

Where conduit protected wiring is used **solely for the sensor cables and is run directly between the sensor and the Aquatrol 2000 controller**, screened cable is not required. Use of the wiring centre is strongly recommended since it provides direct conduit entry.

CONTROLLER INSTALLATION

The controller operates from a 230V 50Hz power supply. Cables providing power to the controller should be sized to match the individual installation requirements for distance and power consumption. The Aquatrol 2000 controller requires an **effective earth directly from the building's consumer unit** in order to meet the same earthing requirements for the temperature sensors.

Each terminal within the controller is capable of accepting either two cables with a maximum cross sectional area of 1.5mm² or one cable with a maximum cross sectional area of 2.5mm². The recommended wiring is as follows:

From Controller to ...	Maximum Length	Type of Wire
Temperature sensors	100m)
Remote unit	50m) To meet the
Boilers/Burners	100m) requirements
Motorised Valves	100m) of local
Pumps	100m) standards
Other devices	100m)

The cable lengths may exceed the maximum values above provided that the cable resistance does not exceed 10Ω and the capacitance does not exceed 10,000pF.

Heating Wiring Notes

The boiler high limit thermostat must always be used and it is recommended that the boiler control thermostat, supplied as an integral part of the boiler, is retained and adjusted to its maximum setting for use as a second high limit thermostat.

The diagrams right are intended to indicate the general principle; the method to actually meet these requirements may vary from installation to installation. In all cases, the boiler control and high limit thermostats and the 230V 50Hz relays, are supplied by others.

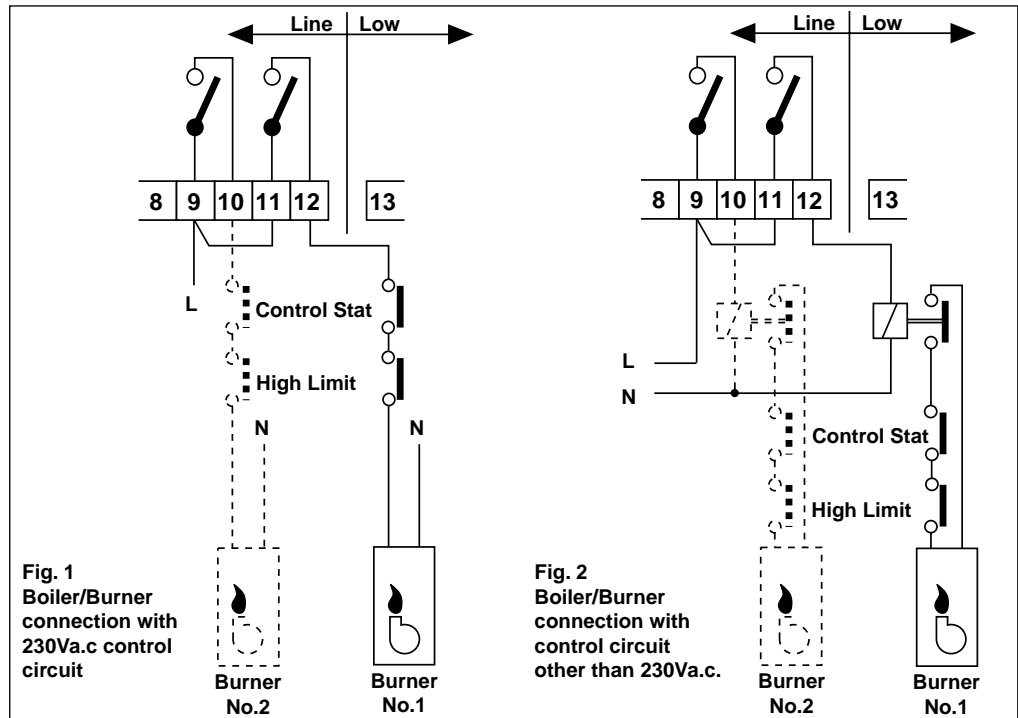

DHWS Wiring Notes

The diagrams right are intended to indicate the general principle; the method to actually meet these requirements may vary from installation to installation. In all cases, the 230V 50Hz relays, are supplied by others.

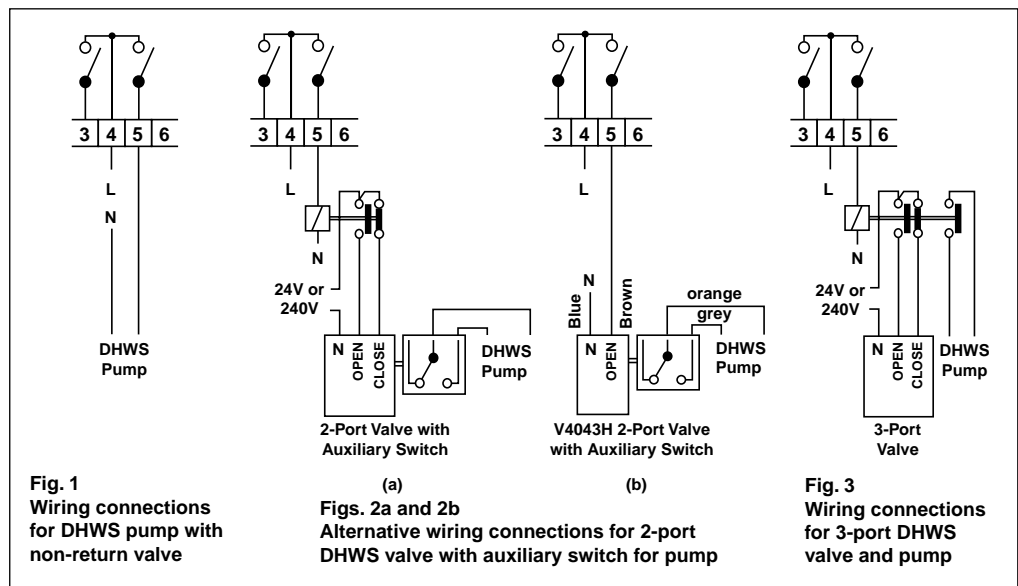

Combined Constant and Variable Temperature Circuits Wiring Notes

The diagram right indicates the need to ensure that the heating pump continues to run in order to dissipate any residual heat after the demand for hot water is no longer required for either the heating, DHWS or the constant temperature circuit. The auxiliary contact (by others) provides feedback to the heating pump that the constant temperature plant no longer requires heat.

The time delay relay provides an 'off' delay to match the actual installation. A suitable unit can be purchased from Radio Spares, or equivalent. Radio Spares part numbers:
Relay: 353-578.
Socket: 353-590.
Off delay timer module (0.1s to 10h): 374-878.

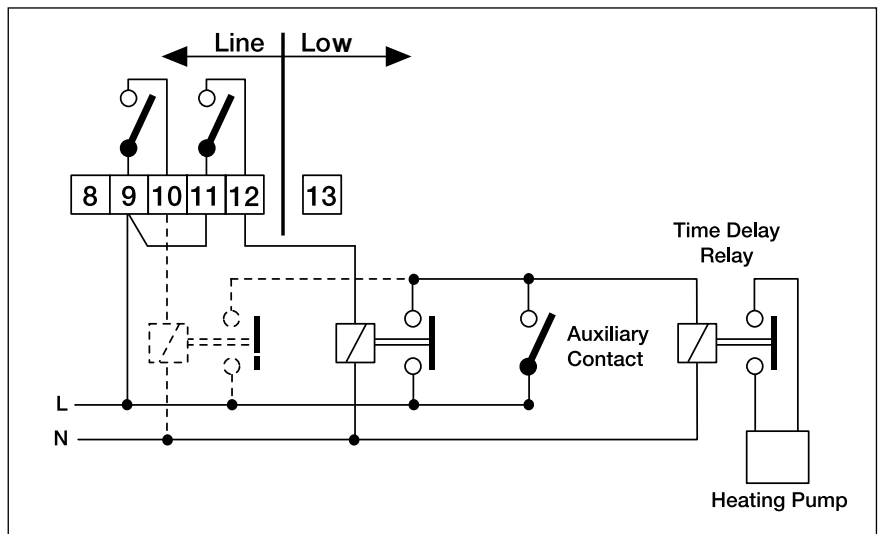

Multiple Boiler Sequence Wiring Notes

When more than two boilers are required to operate in sequence a step controller is required. The step controller uses the mixing valve output terminals making this unsuitable for those AquaPlans needing a mixing valve for correct operation. This application is only suitable for AquaPlans C, D, J and K.

The diagram right shows the wiring for 12 boilers controlled from the Aquatrol 2000 using two STEP 6-230 step controllers.

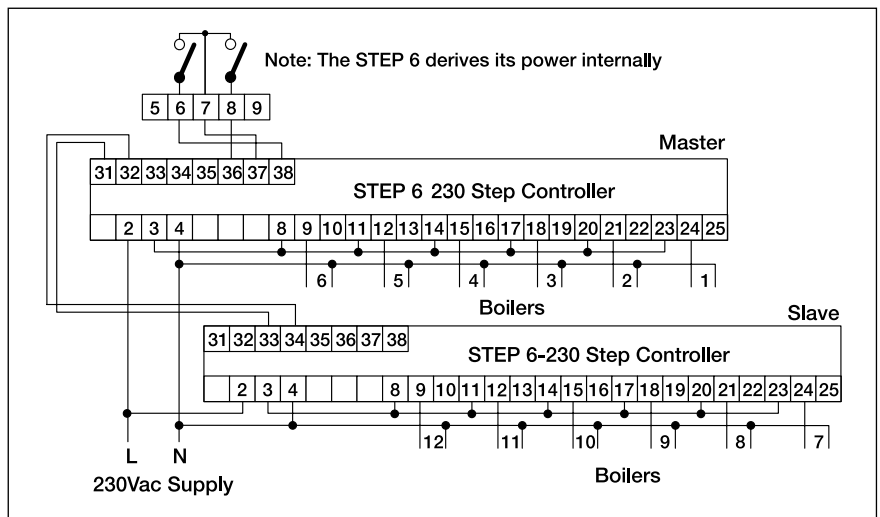

An example of the switch wiring for four boilers in sequence is shown right.

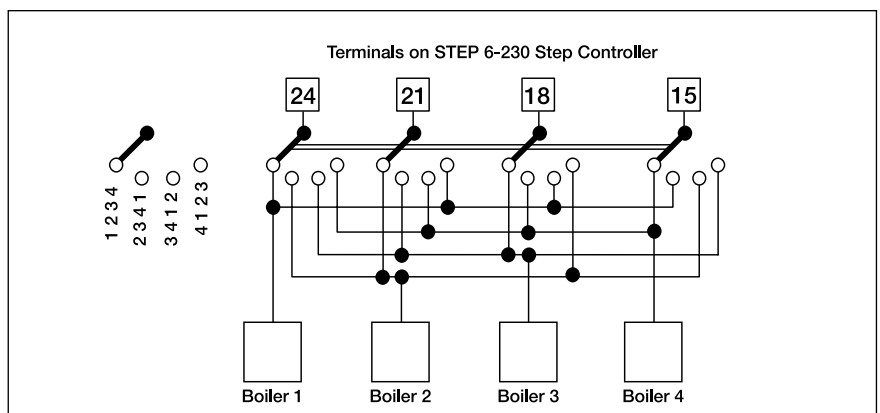

Small Systems Wiring Notes (AquaPlan P and Q)

The diagram right is intended to indicate the general principle; the method to actually meet these requirements may vary from installation to installation.

The motorised valves are the V4043H series from Honeywell and are designed to operate from a 230V 50Hz supply.

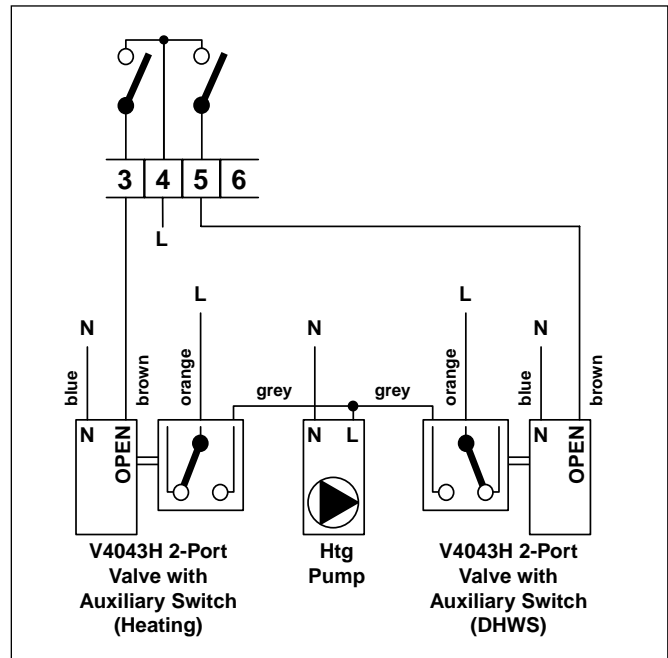

Primary Pump Wiring Notes

Where a boiler primary pump is installed together with a mixing header which serves the compensated heating and DHWS circuits additional relays, external to the Aquatrol 2000 controller are required.

The diagram right shows that either the heating pump or the DHWS output or both will ensure that the primary pump runs to meet the system demand. During summer shut down of the heating, the DHWS temperature sensor is in control of the boiler(s) and a fixed 15 minute pump overrun - occurs to dissipate any residual heat.

Note:
System Selector Switch, S2 must be set to position 'A'.

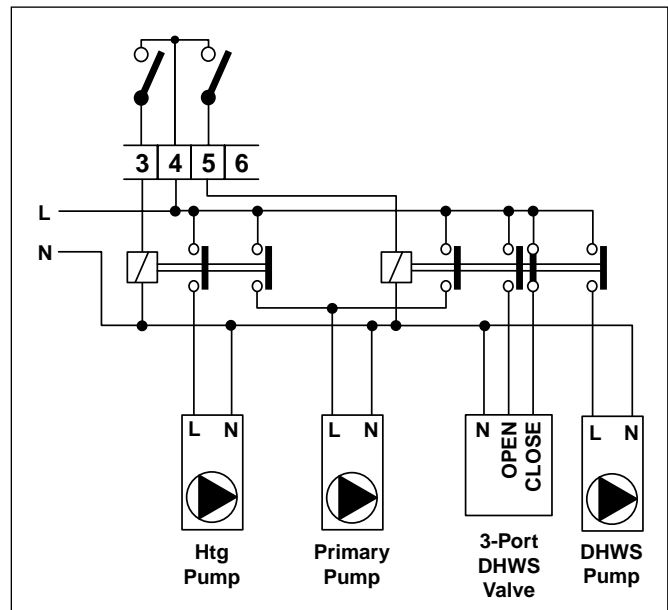

Alternative (Timed) Override

Two fixed resistors can be inserted via a two position manual selector switch (supplied by others) into terminals 22 & 23 normally reserved for the remote unit, as shown in the diagram right. When the run back timer contact is broken, the controller works off its own setpoint settings. When the contact is made, depending on the resistor selected via the selector switch, the controller will be externally switched to its comfort or economy setpoint. The resistor values are as follows:

- Comfort = 4.7K Ω RS Comp Ref 144-324.
- Economy = 3.0K Ω RS Comp Ref 164-334.
- 1% Stability resistors must be used.

Resistors can be purchased from Radio Spares, or equivalent. The run back timer, although marked 'optional', allows a variable override time period to be manually set by the user to specifically match the occasion. The installer needs to determine the maximum variable time period required by the user in order to select the correct timer. Again, this item can be purchased from any reputable supplier such as Radio Spares. Only the heating system is affected.

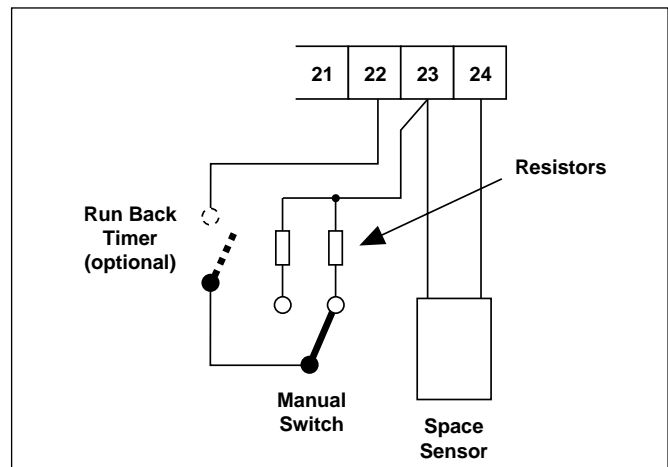

Retro-fit Wiring Notes

The output terminals (6, 7 and 8) to the mixing valve on the heating circuit are only rated for 230V 50Hz actuators. When using any existing valve actuators rated for alternative voltages, the installer may need to insert two relays, supplied by others, with 230V 50Hz coils.

Note that the controller's output relay contacts are rated at 0.25A and, even though other manufacturer's actuators may operate from a 230V 50Hz supply, they may draw a higher current.

If the existing valve actuator is a Honeywell device and you have any doubts, contact your nearest Honeywell branch office (see back cover of this manual) and ask for advice.

All Honeywell actuator part numbers start with either 'M.....' or 'ML.....' followed by 3 or 4 numbers, a single letter and 4 numbers.

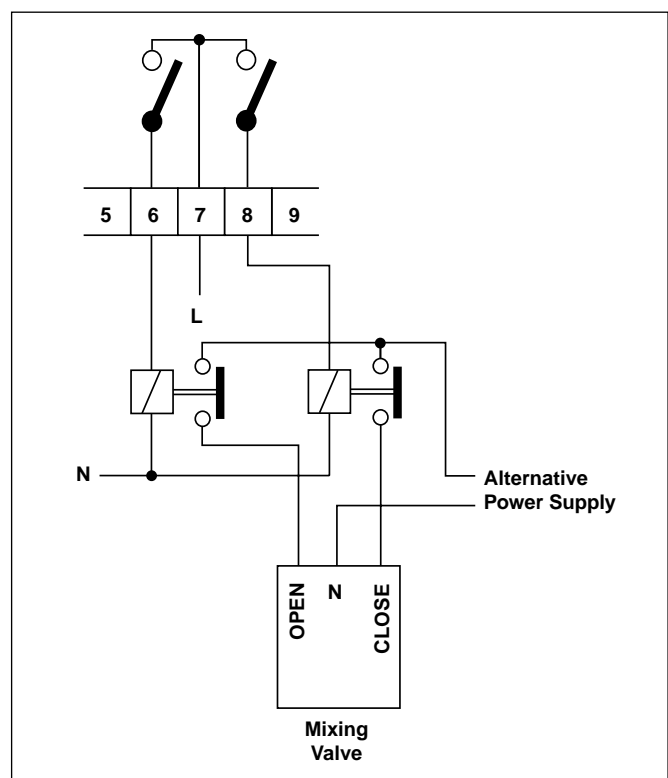

Programming

Touch Key Pad

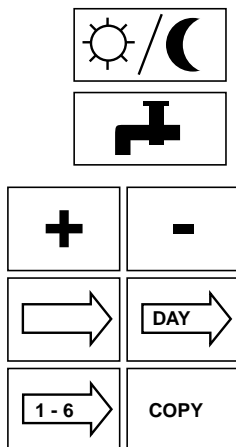



 The Heating Override button is used to change between Comfort and Economy operation whilst in Automatic mode.

 The DHWS Override button is used to change the domestic hot water supply from ON to OFF or from OFF to ON whilst in Automatic mode or DHWS only mode.

Note:
Overrides operate until the next programme switching point.

 The Plus button is used to move the time forward and to set the holiday days.

 The Minus button is used to move the time backwards and to set the holiday days.

 The Programme/Mode Select button is used to move the flag below the top row of symbols on the LCD display to programme the controller or select the operating mode.

 The Day button is used to step through the days of the week when programming the controller.



 The "1 - 6" button serves two purposes:

- 1) Whilst in the programming mode the button is used to step between the 6 switching points that can be programmed each day.

- 2) In temperature enquiry mode it is used to step through the various system sensors.

 The Copy button is used during programming to copy the entire heating or DHWS programme from one day to the next.



To set the Day and/or Time

Press  to move the top flag to .

The display shows the day number and the time.

Note:
Day 1 is Monday

Press  to set the correct day of the week.

Press  or  to set the correct time.

Press  to move the top flag to one of the operating modes.

EXAMPLE

To set the day and time to 14:30 on Tuesday after switching power ON.

Press  to move the top flag to .



The display shows the day 1 and 12:00

Press  to set day 2 for Tuesday.

Press  to set the correct time of 14:30.

Press  to move the top flag to one of the operating modes.



To Set the Programmed Switching Points for the Heating

Press  to move the top flag to .

The display shows Day 1 and the first switching point flag above .

Press  to select the required day.

Press  to select the switching time to be changed.

Press  or  to set the required time.

Press  to select and set the next switching times.

Set any unused switching times to 0:00.

To Copy the Heating Programme to the Next Day

Press to select the day before the day to be programmed.

Press to copy the programme from one day to the next or any subsequent day.

Press to move the top flag to one of the operating modes.

EXAMPLE

To change the second Heating switch time on Tuesday to 8:00

Press to move the top flag to .

The display shows Day 1 and the first switching point flag above .

Press to change to day 2 - Tuesday.

Press to select the second switching time.

Press or to adjust the time to 8:00.

Note:

By using the same procedure switching points to can be altered.

The DHWS switching points can be altered in the same manner.

To Set the Programmed Switching Points for the DHWS

Press to move the top flag to .

The display shows Day 1 and the first switching point flag above .

Press to select the required day.

Press to select the switching time to be changed.

Press or to set the required time.

Press to select and set the next switching times.

Set any unused switching times to 0:00.

To Copy the DHWS Programme to the Next Day

Press to select the day before the day to be programmed

Press to copy the programme from one

day to the next or any subsequent day.

Press to move the top flag to one of the operating modes.

Operating Modes

Automatic
Press to move the top flag to

Standby
Press to move the top flag to

Holiday
Press to move the top flag to



DHWS Only
Press to move the top flag to

To Override the Programmed Switching Points in Automatic Mode

Press to change temporarily from Comfort mode to Economy mode or vice versa.

Press to temporarily change the DHWS from ON to OFF or vice versa.

To View System Temperatures

Press  to move the top marker to .

The display shows the first system temperature.

Press  to step through the various system temperatures.

T1 = Space temperature

T2 = The mixed flow temperature to the system

T3 = Outside air temperature

T4 = The DHWS temperature

T5 = The boiler temperature

P6 = The heating curve ratio (installer information)

Note:

Only the temperatures of the sensors connected will be displayed.

Remote Unit (Optional)

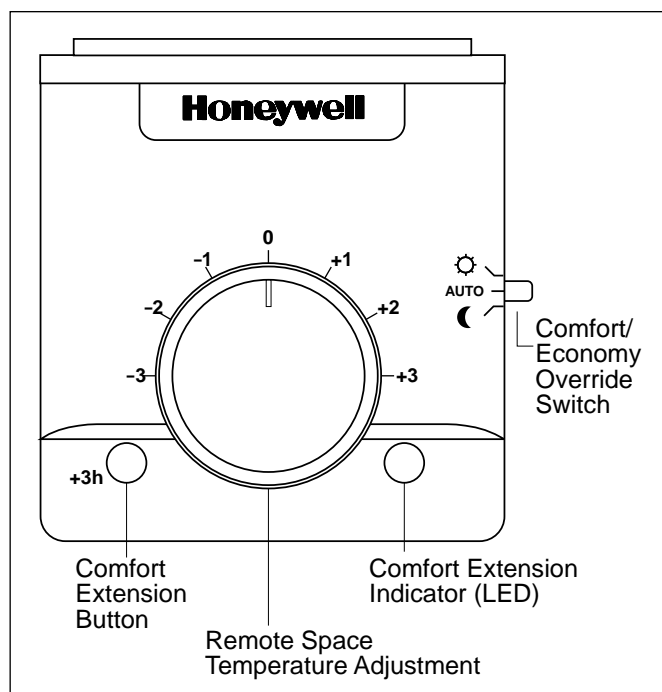





The Remote Unit is a system option which provides a space temperature sensor for the controller and remote controls to allow the user to make adjustments and override the controller without going to the boiler room.

Remote Room Temperature Adjustment

The dial allows the temperature level that has been set on the controller to be increased or decreased by up to 3 degrees depending on the setting of the range stops.

To Set the Holiday Programme

Press  to move the top marker to .

Press  or  to select the number of days holiday.



During the holidays the Heating will control at the Economy setpoint. If no Heating is required the Economy setpoint knob should be set to OFF.

The top flag should be left below the holiday symbol and not returned to the Automatic position (this would cancel the Holiday setting).

The Holiday programme counts down every night at midnight starting from the day set. Normal operation (Automatic Mode) resumes after the programmed period.

Comfort/Economy Override Switch

This switch allows remote override of the controller as follows:

-  Constant Comfort operation
-  Controller follows Automatic programme
-  Constant Economy operation

Comfort Extension Button

If the Comfort Extension Button is pressed when the controller is operating in Comfort mode, then the programmed Comfort period will be extended by 3 hours.

If the Comfort Extension Button is pressed when the controller is operating in Economy mode, then it will immediately switch to Comfort mode for a 3 hour period.

In both cases the Comfort Extension Indicator will come on to confirm the extension.

Once the 3 hour extension has been completed the controller reverts to the previously set mode.

The Comfort Extension can be cancelled at any time by pressing the Comfort Extension Button again. The Comfort Extension Indicator will go out.

Installer Adjustments

Comfort Setpoint

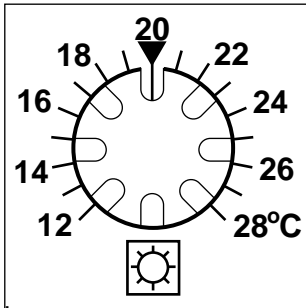

The desired space Comfort temperature can be set within the range 12 to 28°C. The arrow shows the suggested setting of 20°C.

Automatic Summer/Winter Changeover Temperature Setpoint

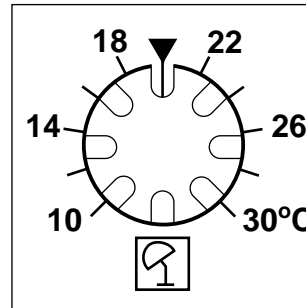

The automatic Summer/Winter changeover temperature setpoint can be set within the range 10 to 30°C. The arrow shows the suggested setting of 20°C. When the average daily outdoor temperature is above the automatic Summer/Winter setpoint the heating will be turned off.

Economy Setpoint

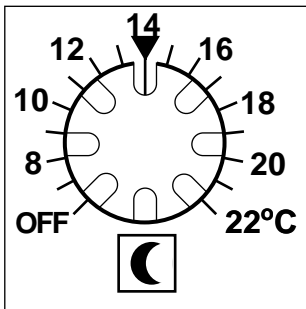

The desired space Economy temperature can be set within the range 8 to 22°C. The arrow shows the suggested setting of 14°C. Night Off can be selected by turning the knob to the OFF position. Frost protection will be active during Night Off.

Cycle Rate Adjustment

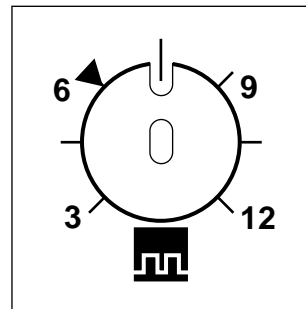

The cycle rate adjustment allows the cycle rate as recommended by the boiler manufacturer to be set directly on the controller. The arrow shows the suggested setting of 6.

Domestic Hot Water Setpoint

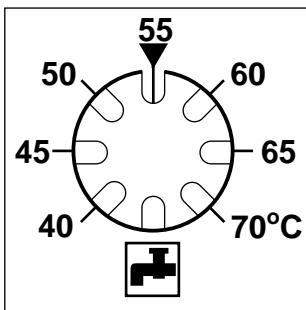

The DHWS temperature can be set within the range 40 to 70°C. The arrow shows the suggested setting of 55°C.

Boiler/Mixed Flow Temperature High Limit

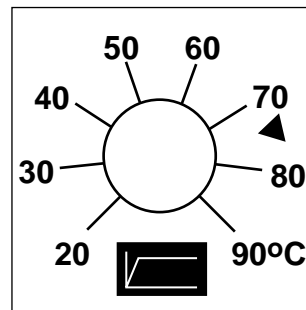

In systems with no mixing valve (no T2 sensor) the maximum value of the boiler supply water temperature (T5) can be adjusted within the range 20 to 90°C. The arrow shows the suggested value of 75°C.

In systems with T2 sensor and mixing valve the maximum mixed water temperature can be adjusted within the range 20 to 90°C. The arrow shows the suggested value of 75°C. The maximum boiler supply temperature in these systems is fixed at 90°C.

In underfloor heating systems this limit temperature must be set to a lower (e.g. 50°C) setting to avoid damage to the underfloor system.

Heating Curve Ratio Adjustment

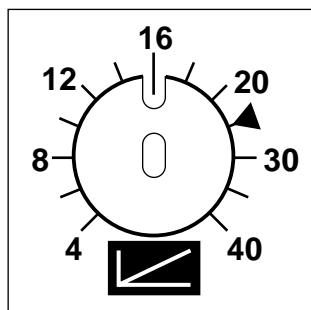

If a Remote Unit and/or Space Sensor is connected the controller's self-adaptive heating curve will operate if system selector switch S7 is in position A.

The heating curve ratio adjustment knob value is the value the self adaption will start from.

Adaption time to the typical value for the location and type of installation can be improved by first selecting position B on switch S7, i.e. removing the self adaption, and then setting a known heating curve value (between 4 and 40) close to the desired one. By returning switch S7 to position A the controller will resume adaptive control from the selected knob value.

If a fixed value of the heating curve ratio is required the switch S7 must be left in position B. This will inactivate the self adaption and the heating curve ratio will be that set on the knob.

If no Remote Unit or Space Sensor is connected to the controller only the set value of the heating curve ratio knob is used. This is independent of the position of switch S7.

To determine the heating curve required refer to the graph below to select the desired value.

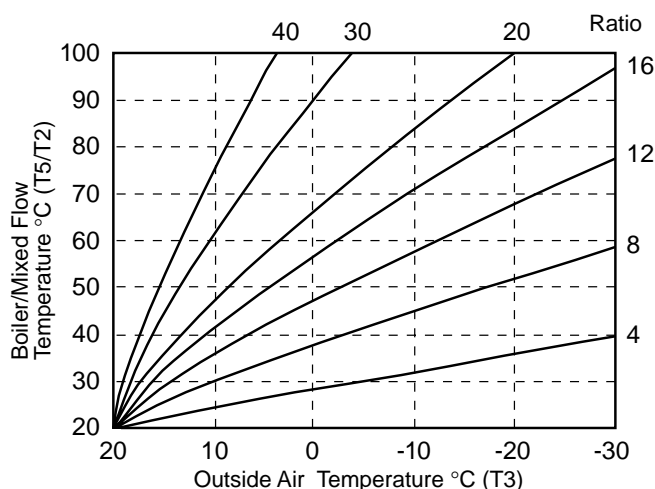

Boiler Setpoint Adjustment

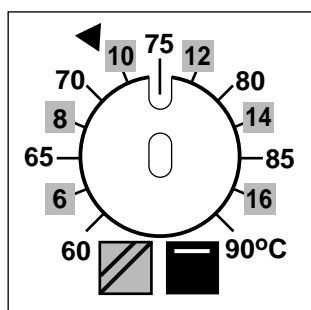

The Boiler Setpoint operates in a different manner depending on the position of System Selector Switch S8.

Boiler/Mixed Flow Differential

(Switch S8 in position A)

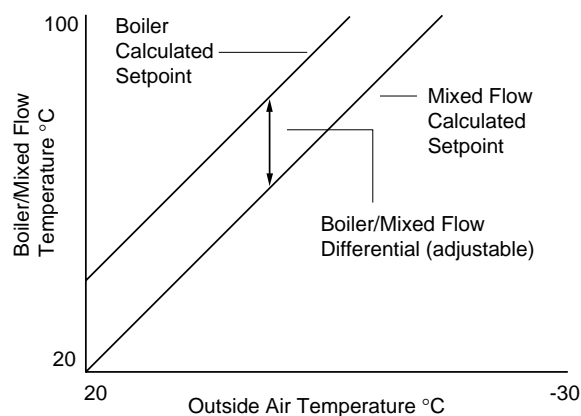

A boiler/mixed flow differential of between 6 and 16K can be set using the Boiler Setpoint knob.

The boiler calculated setpoint plus the set differential. The arrow shows the suggested setting of 10K.

Boiler Minimum Flow

(Switch S8 in position B)

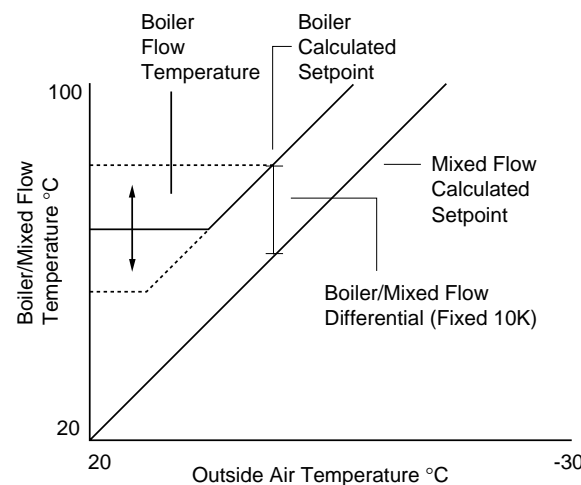

A boiler minimum flow temperature setpoint of between 60 and 90°C can be set using the Boiler Setpoint knob.

The boiler minimum flow temperature will be either the boiler setpoint or the mixed flow temperature plus the fixed differential (10K), whichever is greatest. This has the effect of providing a minimum limit to the boiler temperature for systems requiring a boiler supply temperature which never falls below the set value.

When the controller is operating in the Automatic mode this boiler setpoint will be active from the start of the first Comfort period to the end of the last Comfort period each day and during Comfort Extensions (if a Remote Unit is present).

Typical Specification

One controller shall provide the control functions for sequencing up to two boilers; self-adaptive, optimum start/stop control of the heating plant; self-adaptive, outside air/mixed flow compensated control of the radiator circuit 3-port motorised valve and pump; control of the DHWS valve and/or pump.

The heating and DHWS plants shall have their own independent, seven day per week time programmes with three fully adjustable 'comfort' and 'economy' periods per day.

The controller shall use a software based programme to achieve the control functionality and shall be self configuring based on an automatic sensor detection process. For ease of operation and immediate visual awareness, all user adjustments shall be by analogue knobs as follows:

- [1] Day (comfort) space temperature setpoint.
- [2] Night (economy) space temperature setpoint with night off position.
- [3] DHWS temperature setpoint.
- [4] Summer/winter (heating enable/disable) outside air temperature setpoint.
- [5] Boiler cycle rate to limit the maximum burner firing rate per hour.
- [6] Supply/Mixed flow temperature high limit setpoint.
- [7] Heating curve ratio.
- [8] Boiler/mixed flow differential or boiler setpoint to suit constant temperature circuits supplied with heat from the same boilers used for the variable temperature (radiator) circuit.

These last four functions shall be set by the installer and shall be hidden and protected from unauthorised interference by means of a protective plate.

Manual override switches, not capable of being operated accidentally, shall provide the following functionality:

- [1] Put the complete heating plant into manual control mode, i.e. totally independent of the micro-processor and sensor circuitry.
- [2] Enable the complete heating plant to operate at the boiler high limit setting to enable the service and maintenance technician to functionally test the system under light load conditions.

Programming of the controller shall be simple to achieve with the minimum of key strokes. One of the keys shall provide a copy function to enable the user to initially make the minimum number of key stroke entries. By pressing a button it shall be possible to temporarily override the heating system or the DHWS. It shall also be easy to return to the factory default settings by making no more than two key strokes.

A liquid crystal display (LCD) shall provide the user with the following information:

- [1] Display the current time, day and operating mode for heating and DHWS.
- [2] Indicate the number of days left to expire in the holiday mode. The display shall automatically decrement by one day, each day.
- [3] Indicate that the manual override switch is in operation by displaying the current time.
- [4] Indicate the service switch is in the service mode by displaying the boiler temperature and continuously sounding a beeper.
- [5] Indicate that the controller has automatically switched into summer mode.
- [6] Display the actual values of the temperature sensors connected and the adapted heating curve value or the value for fixed operation when requested by the user.
- [7] Display, in automatic mode, when the programme has entered the phase to optimise the heating plant on or off. The comfort or night symbol respectively on the display shall flash.
- [8] Display the controller's automatic diagnostic fault codes. The unit shall be capable of distinguishing between a short circuit or an open circuit condition at the sensors.
- [9] Indicate the controller's status during custom programming.

The LCD shall also be used during the programming mode to prompt the user/installer. The status of all plant components shall be indicated by means of light emitting diodes (LEDs) on the front of the controller which shall be visible without opening the controller.

In addition to the standard, automatic control functions such as optimum start/stop, outdoor air/mixed flow compensation, heating curve adaption, etc. the controller shall also provide the following automatic functionality:

- [1] Frost protection available by three methods:
 - [a] If the outside air temperature falls below 2°C (with 1K differential) the heating pump shall run and the boiler(s) shall maintain a mixed flow temperature of 30°C for radiator circuits or 15°C for under floor heating circuits.
 - [b] If the space temperature falls below 4°C (with 1K differential) the heating pump shall run and the boiler(s) shall fire to maintain the comfort (day) or economy (night) space setpoint.
 - [c] If the DHWS temperature falls below 10°C (with 5K differential) the DHWS pump shall run and the boiler(s) shall fire.
- [2] Soft start shall operate for the first 15 minutes of the preheat period to restrict the mixed flow temperature to reduce pipe expansion noise.
- [3] Automatic heating shut down shall occur during periods when there is little or no demand for heating. The heating pump shall switch off:
 - if the mixed flow temperature is close to the space temperature setpoint, or
 - when the space temperature is 2K above setpoint, or
 - if the optimum stop period has been activated, or
 - if the user has programmed the heating off, or
 - if the user has manually switched to standby mode or DHWS only mode.If, during the last 30 minutes of the programmed occupancy period, all these conditions revert back to normal, the heating plant shall not switch on again.
- [4] Automatic summer/winter changeover shall occur when the average outside air temperature has been greater than its setpoint for a continuous period of 24 hours. The heating pump and boilers shall be switched off.
- [5] If the programme decides to switch off the heating pump it shall continue to run to dissipate any residual heat for a minimum of 5 minutes or a maximum of 30 minutes or if the boiler water temperature falls below 30°C.

- [6] The 3-port mixing valve and the heating and DHWS valve/pump shall be exercised weekly at 12:00 (noon) each Friday during prolonged shut down periods to prevent sticking or jamming.
- [7] The boiler(s), 3-port mixing valve, heating and DHWS pumps shall follow an automatic start up sequence to assist the installer to prove the correct operation of the heating plant.
- [8] The lead boiler shall be automatically rotated on a weekly basis at 12:00 (noon) each Friday. If the lead boiler is a condensing boiler this feature shall be inhibited.
- [9] If separate DHWS control is required the controller shall enable the DHWS output to be used as a time/temperature channel independent of the heating plant.
- [10] When the DHWS requirements are supplied by the heating boiler(s) it shall be possible to operate the DHWS system in parallel to the heating system (no priority) or give the DHWS full priority or shifting priority.
- [11] On plant shut down, the DHWS pump shall continue to run for a further 15 minutes to dissipate any residual heat.
- [12] In the event of a number of faults occurring together, the controller shall prioritise the faults in order to ensure that the heating plant and the building are operating in the safest manner.

The controller shall be supplied with a matched set of temperature sensors for outside air, immersion or strap-on pipe mounting and space.

The space temperature sensor shall be supplied either as a simple space temperature sensor or a fully functional space sensor with the facility to measure the actual space temperature, adjust the space temperature setpoint by up to $\pm 3\text{K}$, extend the automatic operation by 3 hours or cancel the extension using a simple push-button with LED display and a manual override switch to change the operating mode. The latter functionality shall all be achieved through a two wire connection between the full functional space sensor and the controller. A combination of both the simple space sensor and the full function space sensor shall be possible with the space temperature measurement taken from the simple space sensor.

The manufacturer shall provide a complete range of valves and actuators to meet all applications.

The controller shall be suitable for control panel, wall or DIN rail mounting with terminal blocks capable of accepting two 1.5mm² or one 2.5mm² conductors.

Valves and Actuators – Rotary Plug

M6063L AND V5433A CROVAL ACTUATOR AND 20-50mm VALVES

APPLICATION

The M6063 actuator provides floating control of the V5433A heating valves.

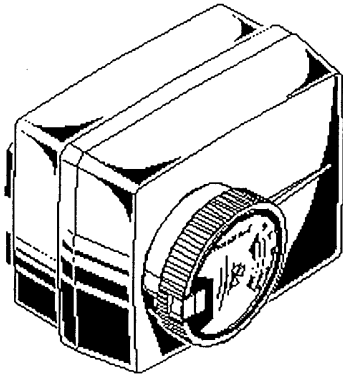

For further details refer to UKOC-0090.

SPECIFICATIONS

Supply voltage	230V 50Hz
Power consumption	3VA
Control signal	230 Vac floating
Angle of rotation	90°
Run time	100s
Torque	5Nm nominal 7Nm stall
Maximum ambient temperature	60°C
Protection class	IP54 according to DIN 40050
Medium temperature	2 to 110°C
Connecting cable	1.5m flying lead
Manual override	Integral in actuator
Model number	M6063L1009

Size	k_v	3-Port Valve
20	2.5	V5433A1015
20	4	V5433A1023
20	6.3	V5433A1031
25	10	V5433A1049
32	16	V5433A1056
40	25	V5433A1064
50	40	V5433A1072

APPLICATION

The valve is specially designed for accurate control of mixed water temperature in heating systems.

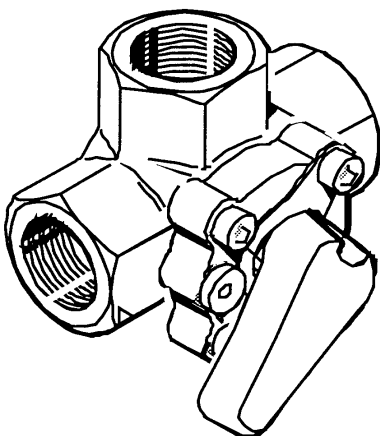

SPECIFICATIONS

Body	Cast iron
Trim	Chrome plated cast iron
Sealing	Double O-ring
Leakage	<1% of k_{vs}
Connections	Internal threads
Angle of rotation	90°
Nominal static press	6 bar
Maximum pressure drop	Refer to literature
Medium	Heating water; water glycol mix (max. 50% glycol according to VDI2035)
Maximum medium temperature	2 to 110°C

For further details refer to UKOC-0089.

Valves and Actuators – Rotary Plug

M6061L ACTUATOR FOR V5431 3-PORT 15-150mm VALVES

APPLICATION

The M6061L is an electric actuator designed for two position or floating operation of the V5431 range of rotary plug valves.

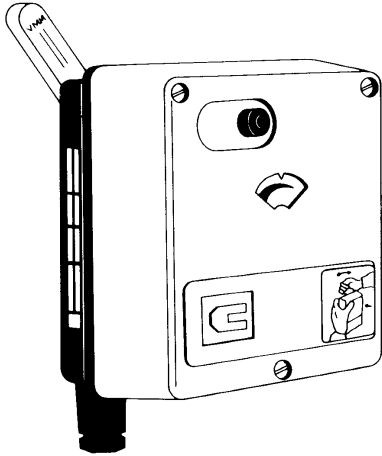

SPECIFICATIONS

Supply voltage	220V/240V +10 -15% 50Hz (optional 240V 50Hz)
Power consumption	3.5VA
Control Signal	SPDT
Torque	10Nm, 20Nm and 30Nm according to type
Max. ambient temp.	60°C
Protection class	IP54
Stroke	90° angular rotation
Timing	10Nm 1.6 minutes 20Nm 2.3 minutes 30Nm 3.5 minutes
Leakage rate	0.1% of k_v with pressure differential of (500mm WG)

Note:

To be used on closed system only.

For further details refer to EN7R-0043/487.

Size		kv	3-Port Valve		Actuator
mm	inch		Screwed	Flanged	
15	½	4	V5431A1025	–	M6061L1019
20	¾	6.3	V5431A1033	V5431F1032	M6061L1019
25	1	10	V5431A1041	V5431F1040	M6061L1019
32	1¼	16	V5431A1058	V5431F1057	M6061L1019
40	1½	25	V5431A1066	V5431F1065	M6061L1019
50	2	40	–	V5431F1073	M6061L1027
65	2¾	63	–	V5431F1081	M6061L1027
80	3	100	–	V5431F1099	M6061L1027
100	4	160	–	V5431F1107	M6061L1035
125	5	250	–	V5431F1115	M6061L1035
150	6	400	–	V5431F1123	M6061L1035

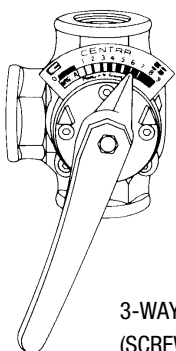

3-WAY VALVE
(SCREWED VERSION)

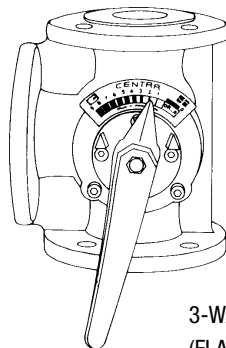

3-WAY VALVE
(FLANGED VERSION)

SPECIFICATIONS

Material	Grey, cast iron
Max. permissible pressure	125 psig (806 bar)
Max. operating temperature	260°F (130°C)
Sealing	O-ring
Angular rotation	90°
Leakage losses	It is not possible to eliminate leakage entirely due to the construction of the rotary valve. In the closed position a certain amount of water may leak across. The extent of this leakage depends upon the differential pressure across the rotary valve. With a differential pressure of 0.7 psi (500mm WG) the leakage is less than 0.1% of the k_v rating.

For further details on 3-port valves refer to K9 Application Manual.

AquaPacks

AQUATROL 2000 PACKAGED CONTROL SYSTEMS

APPLICATION

AquaPacks are complete control systems based on the Aquatrol 2000. Each pack is complete with controller, sensors, actuator and valve. AquaPacks have sufficient sensors to meet all the AquaPlans.

SPECIFICATIONS

Cardboard box with carrying handle containing:

1 off W6060C1067	Aquatrol 2000 controller
1 off T8102B1027	Room sensor
1 off T7043E1008	Outside air sensor
3 off T7044C1002	Clamp-on sensor
1 off M6063L1009	230V 50Hz actuator for V5433A valve
1 off V5433A	3-Port mixing valve (refer to table below)

Plus AquaPlan Application Manual



Part Number	Valve Size
AquaPack 20	20mm
AquaPack 25	25mm
AquaPack 32	32mm
AquaPack 40	40mm
AquaPack 50	50mm

NOTES:

1. Insertion sensors are available, if required.
2. AquaPacks are ordered according to the valve size required.
3. For practical and transportation reasons the valve is packed separately.
4. The W6060C1117 alternative controller (without the automatic boiler rotation feature) is available, if required.
5. AquaPacks are also available with three immersion temperature sensors (complete with immersion wells). To order, add the letter "I" to the Part Number, i.e. AquaPack 40I is a complete packaged control system with a 40mm valve and immersion temperature sensors.

Notes

Notes

Take Control with Honeywell

If you'd like more information on any of the products, services and capabilities Honeywell Building Control can provide, please contact your nearest branch office.

HEAD OFFICE

Honeywell Control Systems Ltd
Honeywell House
Arlington Business Park
Bracknell
Berkshire RG12 1EB
Tel: 01344 656000
Fax: 01344 656240

BRANCH OFFICES

BRACKNELL

Honeywell Control Systems Ltd
Lovelace Road
Southern Industrial Area
Bracknell
Berkshire RG12 8WD
Tel: 01344 656000
Fax: 01344 655454

BIRMINGHAM

Honeywell Control Systems Ltd
2480 Regents Court
The Crescent
Birmingham Business Park
Birmingham
West Midlands B37 7YE
Tel: 0121 480 5200
Fax: 0121 480 5336

BRISTOL

Honeywell Control Systems Ltd
150 Aztec West Business Park
Almondsbury
Bristol BS32 4UB
Tel: 01454 848048
Fax: 01454 848049

DARTFORD

Honeywell Control Systems Ltd
Honeywell House
Anchor Boulevard
Dartford
Kent DA2 6QH
Tel: 01322 484800
Fax: 01322 484898

MANCHESTER

Honeywell Control Systems Ltd
Honeywell House
856 Wilmslow Road
Didsbury
Manchester M20 2HY
Tel: 0161 2514000
Fax: 0161 2514141

MOTHERWELL

Honeywell Control Systems Ltd
Block 1A
Scottish Sales & Service Office
Newhouse Industrial Estate
Newhouse
Motherwell
Lanarkshire ML1 5SB
Tel: 01698 481048
Fax: 01698 481113

SCUNTHORPE

Honeywell Lincold Holdings Ltd
Atkinson Way
Foxhills Industrial Park
Scunthorpe
North Lincolnshire DN15 8QJ
Tel: 01724 866623
Fax: 01724 280980

SHEFFIELD

Honeywell Control Systems Ltd
119 Psalter Lane
Sheffield
South Yorkshire S11 8YR
Tel: 01142 556451
Fax: 01142 585088

SUNDERLAND

Honeywell Control Systems Ltd
3D Colima Avenue
Sunderland Enterprise Park West
Wessington Way
Sunderland SR5 3XB
Tel: 0191 5168044
Fax: 0191 5168800

COMFORT COOLING PLC

2nd Floor, Catherine House
Three Cherry Trees Lane
Hemel Hempstead
Herts HP2 7RP
Tel: 01442 424480
Fax: 01442 424495

KODEN MAINTENANCE

Koden House
Back Lane
Rochford
Essex SS4 1AY
Tel: 01702 549681
Fax: 01702 547843

Aquatrol is a trademark of Honeywell Ltd

AquaPlan is a trademark of
Honeywell Control Systems Ltd

Comfort from Experience™

Honeywell

Home and Building Control Products

Honeywell Control Systems Limited
Honeywell House
Arlington Business Park
Bracknell
Berkshire RG12 1EB
Telephone: 01344 656000
Facsimile: 01344 656240